

ARM Based Solar Tracking System

SHASHAVALI, G SWETHA

Assistant Professor, M.TECH STUDENT

Dept of ECE, Megha Institute of Engineering & Technology For womens, Edulabad, Ghatkesar mandal, Ranga Reddy Dist, Telangana, India

ABSTRACT: Solar energy systems have emerged as a viable source of renewable energy over the past two or three decades, and are now widely used for a variety of industrial and domestic applications. Such systems are based on a solar collector, designed to collect the sun's energy and to convert it into either electrical power or thermal energy. In general, the power developed in such applications depends fundamentally upon the amount of solar energy captured by the collector, and thus the problem of developing tracking schemes capable of following the trajectory of the sun throughout the course of the day on a year. This project is designed with ARM7TDMI processor. The ARM7TDMI processor does the job of fetching the input from the sensor and gives command to the motor to run in order to tackle the change in the position of the sun.

Keywords: Solar collector, Light Dependent Resistor (LDR), ARM7TDMI processor.

I. INTRODUCTION

Solar energy is the energy extracted from the rays issued from the sun in the form of heat and electricity. This energy is essential for all life on Earth. It is a renewable resource that is clean, economical, and less pollution compared to other resources and energy. Therefore, solar energy is rapidly gaining notoriety as an important means of expanding renewable energy resources. As such, it is vital that those in engineering fields understand the technologies associated with this area. Our paper includes the design and implementation of a microcontroller-based solar tracking system. Solar tracking allows more energy to be produced because the solar panel is tracking the maximum power point of the sun's position.

To get an efficient solar tracker system, a small solar panel is used instead of a large one to obtain a graphical position data of the sun when it is detected and send this data to the large panels. This system can be installed anywhere in the world without knowing the sun directions and seasons.

II. SOLAR SYSTEM TRACKER

A solar tracker is an electro-mechanical system used on behalf of orienting a solar photovoltaic panel in the direction of the sun. It is used in many applications such as the transportation signaling, lighthouses, emergency phones installed in the highways, etc... Its main objective is to find the maximum sun radiations in order to get maximum charge for the batteries. Electricity can be generated from the sun in several ways. Photovoltaic's (PV) has been mainly developed

for small and medium-sized applications, from the calculator powered by a single solar cell to the PV power plant. For large -scale generation, concentrating solar thermal power plants have been more common, however new multi-megawatt PV plants have been built

recently. A photovoltaic cell (PV cell) is a specialized semiconductor that converts visible light into direct current (DC). Some PV cells can produce DC electricity from infrared (IR) or ultraviolet (UV) radiation. Photovoltaic cells are an integral part of solar-electric energy systems, which are becoming increasingly important as alternative sources of power utility. Solar cells generate DC electricity from light, which in turn can be used in many applications such as: charging batteries, powering equipment, etc. They produce currents as long as light shines, as shown in Fig.1.

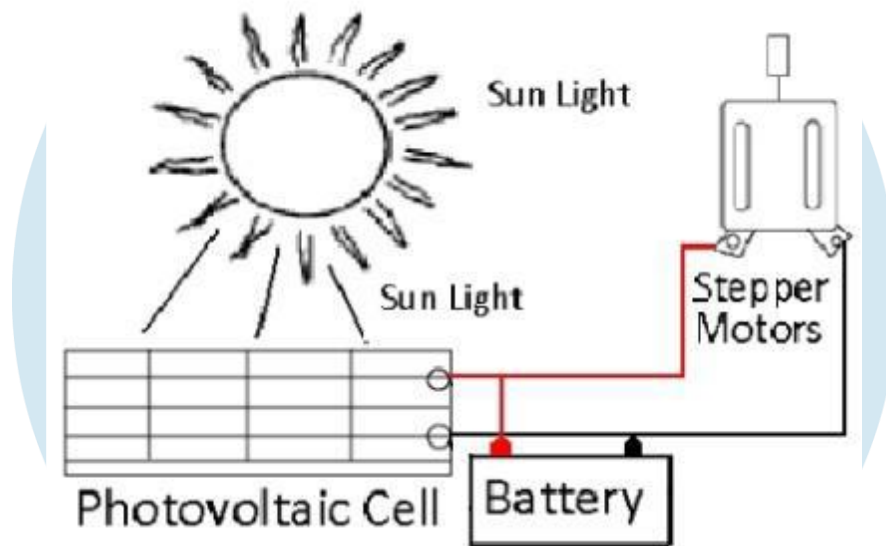

Figure1. block diagram of the solar energy system

The detection of the position of the sun undergoes several steps as shown in Fig.2. A digital system (LPC2148) is used to calculate the maximum sun radiation. It is connected to a stepper motor and to light dependent resistors to redirect the panel to the sun. It sends the received data (position of the sun) to the stepper motors in order to position it toward the sun. The position angles are stored in the processor registers and can be displayed on an LCD or can be transmitted to a remote system.

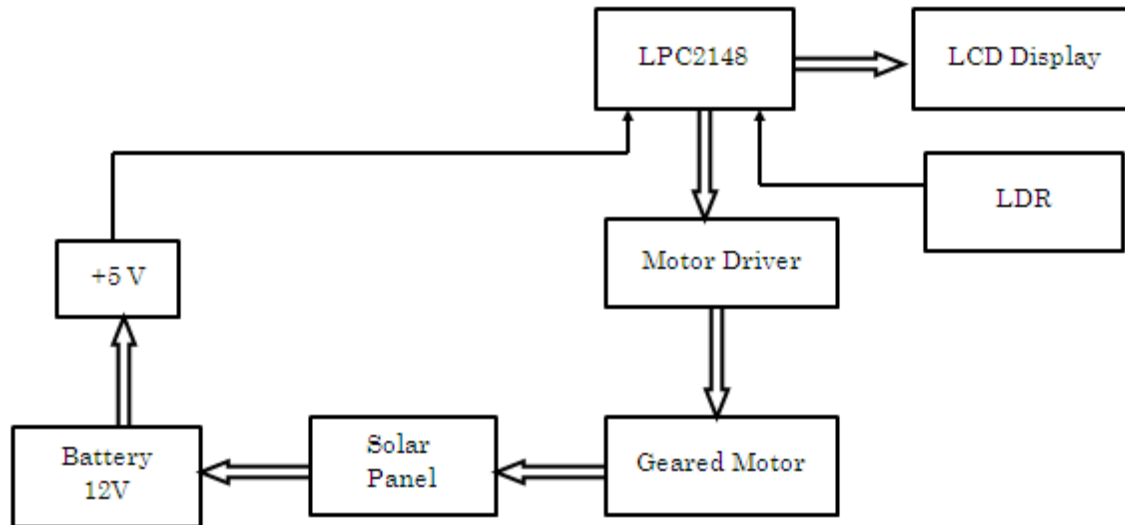

Figure2. block diagram of the solar tracker

2.1 Solar Tracker A solar tracker is an electro-mechanical device for orienting a solar photovoltaic panel toward the sun trackers, especially in solar cell applications require a high degree of accuracy to ensure that the concentrated sunlight is directed precisely to the powered device.

Solar trackers can be active or passive and may be single axis or dual axis. Single axis trackers normally use a polar mount for maximum solar efficiency and employ manual elevation (axis tilt) adjustment on a second axis, which can be adjusted regularly during the year. Trackers can be relatively inexpensive for photovoltaics. This makes them especially effective for photovoltaic systems using high-efficiency panels. Solar trackers usually need inspection and lubrication on a regular basis. Active trackers, which use motors and gear trains, are controlled by an electronic circuit responding to the solar direction.

2.2 Applications

In this paper a solar tracker is realized to capture maximum power from sunlight. The position of maximum capture of power is stored in memory. The stored data can be applicable for many applications such as Large photo voltaic panels can track the sun all the day light and by that it give above 65% efficiency in generating electricity. Solar heaters will also track the sun all the day light and by that less panels are required at the initial cost while in the home automation systems, this system is also needed in turning light ON and Off and also for opening and closing the curtains.

III. HARDWARE IMPLEMENTATION

3.1 Solar Panel

A photovoltaic module or photovoltaic panel is a packaged interconnected assembly of photovoltaic cells, also known as solar cells. A typical silicon PV cell is composed of a thin wafer consisting of an ultra-thin layer of phosphorus-doped (N-type) silicon on top of a thicker layer of boron-doped (P type) silicon. Regardless of size, a typical silicon PV cell produces about 0.5 – 0.6 volt DC under open-circuit and no-load conditions. The current (and power) output of a PV cell depends on its efficiency and size (surface area), and is Proportional to the intensity of sunlight striking the surface of the cell. The photovoltaic module, known more commonly as the solar panel, uses light energy (photons) from the sun to generate electricity through the photovoltaic effect. The majority of modules use wafer-based crystalline silicon cells or a thin-film cell based on cadmium telluride or silicon. Crystalline silicon, which is commonly used in the wafer form in photovoltaic (PV) modules, is derived from silicon, a commonly used semiconductor. The solar panel used in the proposed system is of 4W power rating as shown in Fig.3.



Figure3. 4W Solar Panel

3.2 Stand Assembly

The frame for the solar panel is made up of L shaped steel rod. The length is 0.95m and width is 0.38m. A square plate of dimensions 28x30 cm is made out of iron plate is fixed to the main structure at the height of 90cm from the base. The main frame is also made up of L shaped iron rod. Fig.4 illustrates stand assembly.



Figure4. Stand Assembly

3.3 Sensors

Sensor can be defined as a device which receives a signal and converts it into electrical form which can be further used for electronic devices. The light dependent resistors (LDR) are used in the circuit to sense the change in the sun's position. A photo resistor or light dependent resistor or cadmium sulphide (CdS) cell is a resistor whose resistance decreases with increasing incident light intensity. A photo resistor requires a power source because it does not generate Photocurrent a photo effect is manifested in the change in the material's electrical Resistance. Fig.5 shows a photo resistive cell.

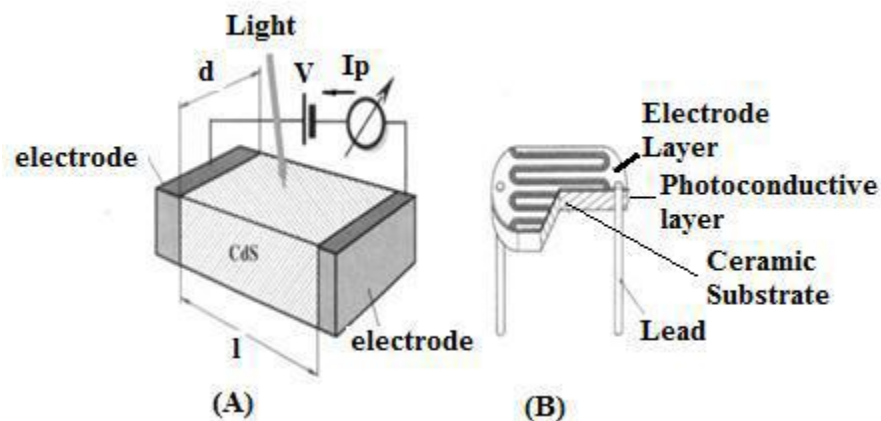

Figure5. (A) Structure of a photo resistor and (B) a plastic-coated photo resistor having a serpentine shape

3.4 ARM Processor:

LPC 2148 is a microcontroller with an internal ARM processor. In this project it gets signals from the light dependent resistors and is used to drive a geared motor to get maximum intensity of light. For this, the microcontroller uses PWMTCR, PWMTC, PWMPR, PWMP, PWMMR0, PWMMCR, and PWMPCR register to control the direction of the solar panel using pulse width modulation. Fig.6 shows LPC2148 mother board.

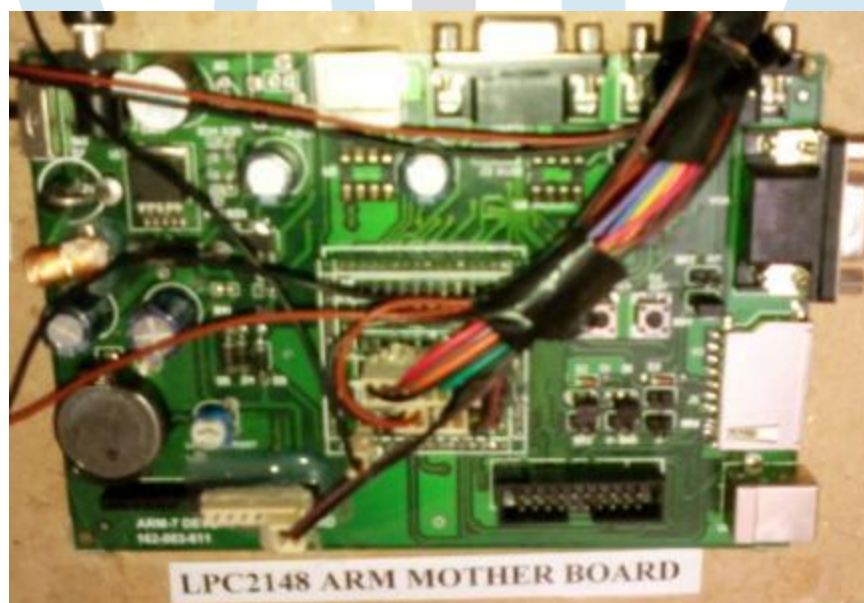

Figure.6. LPC2148 Mother Board **3.5 Geard motor:**

The motor chosen for the proposed system is 12V motor with 60rpm, coupled with a worm gear. The gear ratio is 25:1. The main reason for the selection of the geared motor is that it will consume very less power for a very small

span of time. Also the torque required to rotate heavy PV arrays is sufficient enough. Fig.7 shows a 12V dc geared motor of 60RPM.



Figure.7. 12V geared motor

IV. CONTROL ALGORITHM AND PRIMARY RESULTS

4.1 Control Algorithm

In order to demonstrate the efficiency of the proposed system, a control algorithm is generated as shown in TABLE I, which is illustrated in Fig.8.

TABLE I. CONTROL ALGORITHM

Step #	Action
1	Install the small PV
2	Put PV in initial position (0,0)
3	Find the maximum sun light, using the photo resistors, and save the position of the PV
4	Measure the current (I)
5	If $I <$ threshold value (minimum current) wait for 30 minutes and go to step 3, otherwise go to step 6
6	Turn PV left for 3.5° , measure the current if it is greater than the previous current continue turning left until finding the maximum Current in x and y axis.
7	Send the coordinates (x,y) of the solar panel to the processor.
8	Go to step 3

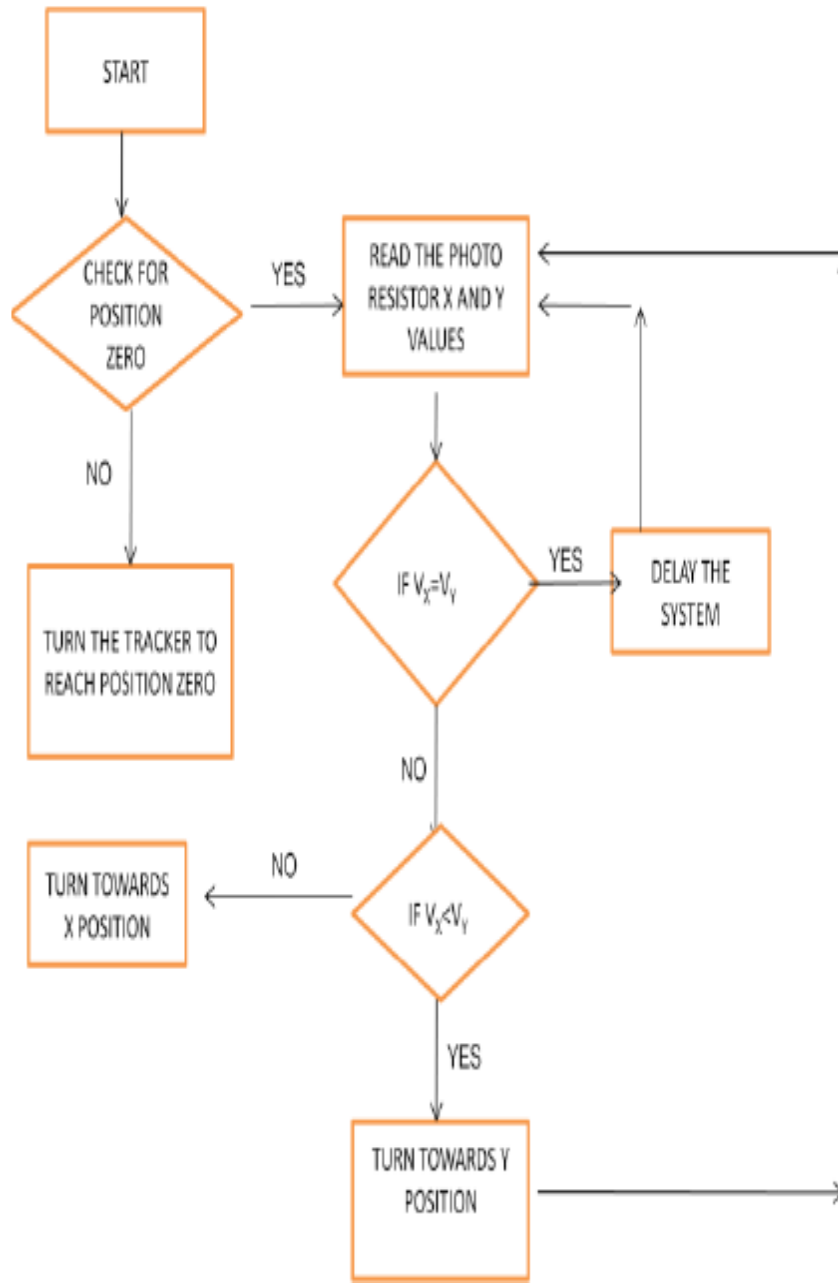

Figure.8. control algorithm

4.2 Preliminary Results

In order to assess the efficiency of the proposed system, some measurements were taken during a sunny summer day. TABLE II shows the comparison between the maximum current using a fixed Photovoltaic panel (PV) and using the proposed system at different times.

TABLE II. COMPARISON OF THE CURRENT BETWEEN FIXED PV AND USING THE PROPOSED SYSTEM

Time	Current using a fixed PV(mA)	Current using the Proposed system (mA)
08:00 AM	0.42	0.85
09:00 AM	0.55	0.90
10:00 AM	0.75	0.92
11:00 AM	0.81	0.95
12:00 PM	0.92	0.99
01:00 PM	0.95	0.99
02:00 PM	0.88	0.99
03:00 PM	0.76	0.98
04:00 PM	0.42	0.95
05:00 PM	0.23	0.95
06:00 PM	0.08	0.72
Total	6.84	10.39

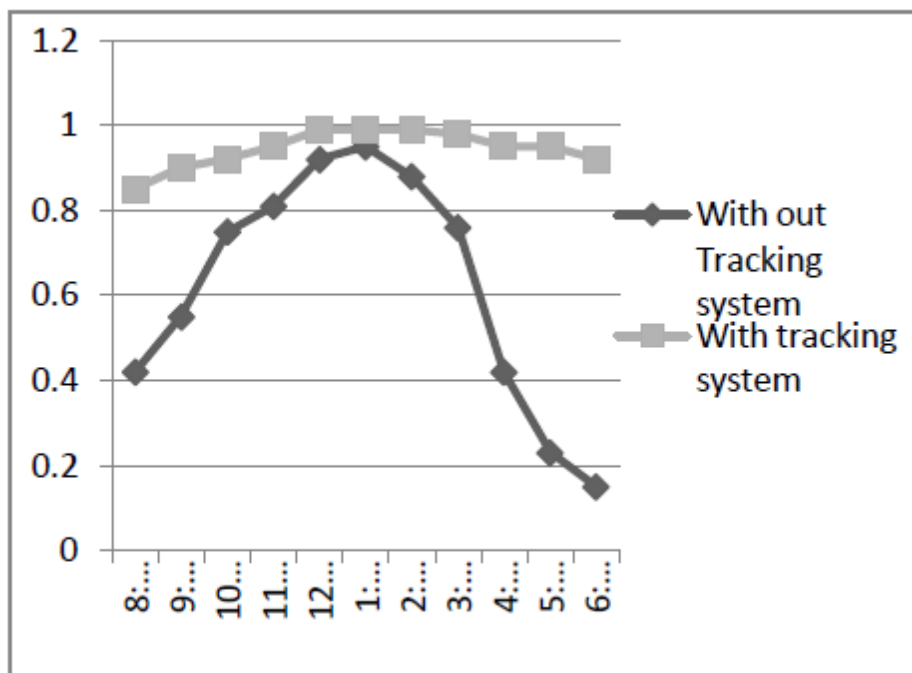

Figure.9. Efficiency of the Solar Tracking system

The Fig.9 shows the efficiency of the tracking system. It seems that the efficiency of the proposed system can be increased around 64% on a summer sunny day. In addition, the proposed system consumes little power to turn the PV

panel using a stepper motor instead of using large panel which consumes high power. Moreover, this system can power itself from the PV panel using a 12V battery.

V. CONCLUSION

This project reports a “LPC2148 Based Improved Structure of Solar Tracker”. The Monitoring controller based on the closed loop algorithm is designed and implemented with ARM7 TDMI processor based LPC2148 controller in embedded system domain. Experimental work has been carried out carefully. By using this project maximum current can be obtained from solar panel. Solar trackers are devices used to orient photovoltaic panels, reflectors, lenses or other optical devices towards the sun. Since the sun’s position in the sky changes with the seasons and the time of day, trackers are used to align the collection system to maximize energy production.

REFERENCES

This heading is not assigned a number.

- [1] A. Zahedi, “Energy, People, Environment, Development of an integrated renewable energy and energy storage system, an uninterruptible power supply for people and for better environment,” *The International Conference on Systems, Man, and Cybernetics, 1994. 'Humans, Information and Technology', Vol. 3 pp. 2692-2695, 1994.*
- [2] R. Singh, and Y.R. Sood, “Transmission tariff for restructured Indian power sector with special consideration to promotion of renewable energy sources”, *The IEEE Conference TENCON-2009, pp. 1-7, 2009.*
- [3] J. Arai, K. Iba, T. Funabashi Y. Nakanishi, K. Koyanagi, and R. Yokoyama, “Power electronics and its applications to renewable energy in Japan,” *The IEEE Circuits and Systems Magazine, Vol. 8, No. 3, pp. 52-66, 2008.*
- [4] S. Takemaro and Shibata Yukio, “Theoretical Concentration of Solar Radiation by Central Receiver Systems,” *The International Journal of Solar Energy, 261-270, 1983.*
- [5] S. Armstrong and W.G Hurley “Investigating the Effectiveness of Maximum Power Point Tracking for a Solar System”, *The IEEE Conference on Power Electronics Specialists, pp.204-209, 2005.*
- [6] O. Aliman, and I Daut, “Rotation-Elevation of Sun Tracking Mode to Gain High Concentration Solar Energy”, *The IEEE International Conference on Power Engineering, Energy and Electrical Drives, pp.551-555, 2007.*
- [7] A.K. Saxena and V. Dutta, “A versatile microprocessor- based controller for solar tracking”, *IEEE Proc., 1990, pp. 1105 – 1109.*
- [8] E. Karatepe, T. Boztepe, and M. Colak, “Power Controller Design for Photovoltaic Generation System under Partially Shaded Insolation Conditions”, *The International Conference on Intelligent Systems Applications to Power Systems, pp. 1-6, 2007.*
- [9] N. Barsoun, “Implementation of a Prototype for a Traditional Solar Tracking System”, *The Third UKSim European Symposium on Computer Modeling and Simulation, pp. 23-30, 2009.*

[10] C. Jaen, J. Pou, G. Capella, A. Arias, and M. Lamich, M, “On the use of sun trackers to improve maximum power point tracking controllers applied to photovoltaic systems”, *The IEEE conference on Compatibility and Power Electronics*, pp. 67-72, 2009.

