

SENSOR DRIVEN-HUMANOID ROBOT FOR EFFICIENT GUEST DETECTION AND INTERACTION

Rekha R¹, Ramesh S², Shalini D³, Yuvasri N⁴, Muthu Bharath V⁵,

¹ Assistant Professor, Department of Electronics and Communication Engineering

Tamilnadu College Of Engineering, Coimbatore, Tamilnadu, India

^{2,3,4,5} Department of Electronics and Communication Engineering

Tamilnadu College Of Engineering, Coimbatore, Tamilnadu, India

ABSTRACT

More places open to the public now rely on machines that act without constant human help. What follows describes how a life-sized robotic figure senses guests and responds. At its core sits an ESP32 chip handling decision tasks. When someone comes near, either sound waves or heat signals spot them. Then, without waiting, spoken words stored earlier come through a speaker device. Moving like people - hands waving, heads turning - is possible because of servo motors. Visual cues pop up for guests through a screen tucked into the setup. Less strain on staff happens while messages stay steady over time. Spending stays low with this design, fitting well inside schools, clinics, workplaces, and similar spots open to the crowd. Smarts might grow later by adding systems that see faces, understand speech, or learn patterns.

Keywords: Humanoid Robot, Guest Detection, ESP32, Ultrasonic Sensor, Human-Robot Interaction.

1. INTRODUCTION

Nowadays, humanoid robots show up more often in automated setups. Built to work alongside people, they communicate in ways that feel smooth and normal. Places like universities, medical centers, lodges, or business buildings need help greeting visitors - this job matters quite a bit.

Folks used to handle these tasks up front, one by one. Still, doing it that way means someone must always be on duty, which adds up in expenses. Machines taking over bring smoother runs, fewer hiccups along the day. Something moves when someone arrives - this robot notices, then says hello. Built with sensors, it picks up people nearby, reacting through sound plus motion that's basic but clear. Cost matters here; keeping it affordable opens doors for schools or labs to try building one too. Not flashy, just functional - a helper shaped like a person, ready to greet without help.

2. LITERATURE SURVEY

Few fields have stayed under study quite like robots shaped like people. Over time, ways to make these machines connect better with humans began shifting - new methods popped up alongside older ones. Instead of just focusing on movement, attention moved toward how they respond, behave, listen. Progress crept in through small changes rather than sudden leaps. Machines meant to assist started feeling less stiff, more tuned in. Each step forward came not

from one big idea but several quieter efforts feeding into each other.

Now machines shaped like people are showing up more in hotels and travel spots. With a nod or beep, they guide guests around, reply to simple queries, even say hello at entrances. Nowadays, some studies look at robots that help people by talking, moving their bodies, or showing images on screens. Often found in hospitals or homes for older adults, these machines work alongside humans without taking over physical tasks. Robots sometimes notice people through infrared beams, sound waves, or camera inputs - this awareness comes from tools built into their frames. When something moves nearby, these gadgets spark a reaction without needing buttons or signals.

Even with progress, plenty of current setups come with high costs plus demand tricky coding spaces. So - simple embedded hardware might open doors if affordable human-shaped robots fill that gap. A tiny computer powers the robot built for this task, using parts that save money. Though small, its design handles complex moves through smart engineering. From basic pieces comes a figure able to mimic human motion. With affordable materials, movement becomes possible without high expenses. Built around simplicity, it responds like a person but runs on simple rules.

3. RESEARCH METHODOLOGY

A closer look at how the project unfolds begins with planning each phase carefully. Following that blueprint, building the robot moves through stages like shaping its structure first. Then comes connecting physical parts so everything fits and functions together. Afterward, coding brings movement and responses to life step by step. Testing happens continuously, making sure reactions stay consistent during real interactions. What results is a machine able to notice visitors clearly while responding appropriately.

3.1 System Design Approach

A fresh twist on embedded architecture shapes how this setup works. Built around microcontrollers, it links up sensors along with communication parts to handle visitor exchanges automatically - actuators join in to make moves happen when needed.

The design process consists of the following stages:

Requirement Analysis
Hardware Selection
System Architecture Design
Circuit Development
Software Programming
Prototype Implementation
System Testing and Evaluation

Step by step, pieces come together building a working humanlike machine. From one phase into the next, movement grows clearer. Parts connect through careful design, shaping how it stands. With every shift, balance improves slightly. Progress moves quietly but steadily forward.

3.2 Requirement Analysis

Right off the bat, figuring out what the robot needs to do comes into play. What stands out most? Tasks it must handle every time. One thing leads to another - movement, sensing, reacting. Each job ties back to how well it works in real situations. Key abilities start shaping up once basics are clear. Step by step, purpose begins to show through actions

Detection of human presence near the robot
Automatic greeting of visitors
Human-like gestures using servo motors
Visual message display
Continuous autonomous operation

A budget-friendly setup works well when it runs without issues, yet stays simple enough for classroom use. While cost matters, dependability holds equal weight, especially if students must build it themselves. Simplicity enters the picture because clarity speeds up learning, though durability still counts. Even a basic design can perform consistently, provided steps are clear and parts easy to find.

3.3 Hardware Selection

Choosing hardware parts came down to price first, then how well they work. Performance mattered just as much as being easy to find. Availability played a role, especially if delays could happen. Compatibility tied it all together - without it nothing connects right.

Selected Hardware Components
ESP32 Controls System Ultrasonic And IR Sensors Detect Presence
DFPlayer Mini Plays Voice Messages Speaker Outputs
Audio Servo Motors Move Hands And Head LED Panel Shows Greetings
7805 Regulator Provides Stable Power

Together, these parts formed the first version of a human-shaped robot.

3.4 System Architecture Development

A web of connections links each hardware piece, built so signals flow without pause. Built into the design: constant contact, no delays, just steady talk across parts.

A setup built using several working parts. Each section handles a task on its own. One piece links to another, forming connections that matter. Parts fit together without extra pieces hanging loose. Every block does what it needs to do

Sensor Input Module
Processing Unit (ESP32)
Motion Control System

Audio Output System
Visual Display Module
Power Management System

From inside the setup, the small computer grabs info from sensors while handling every device it sends signals to. It runs things by taking measurements plus managing what gets turned on or off around the system.

3.5 Circuit Design and Integration

A network of sensors, motors, and wireless parts came together around an ESP32 chip to form the system. While linking each piece, the setup took shape through careful placement and wiring. Because every component needed a stable connection, attention shifted to how they interacted electrically. Once hooked up properly, signals began moving between devices without delay.

Over by the wall, an ultrasonic sensor keeps watching what's nearby. Once someone steps close - within set limits - it tells the brain of the system. That small computer turns on the speaker piece, the screen, along with moving parts that shift position.

A steady 5V feed reaches the system thanks to the A7805 regulator. This setup works just as well on a breadboard as it does when built onto a PCB.

3.6 Software Development

Running on an ESP32 chip, the humanoid robot's software came together through embedded coding. Built into its core, the program runs without needing outside help. From early tests, performance stayed stable under changing conditions. Code adjustments happened directly on the hardware during trials. Each update tightened response times a little more. Focused only on real tasks, features grew step by step. Over time, small tweaks added up to smooth operation.

The program performs the following functions:

Reading sensor input signals
Processing distance data
Detecting human presence
Activating greeting voice message
Controlling servo motor movements
Displaying greeting text

A steady cycle keeps the system running, so the robot notices when someone arrives then acts without help.

3.7 Prototype Development

From metal limbs to wiring, pieces came together into a frame shaped like a person. Built step by step, the machine took form through careful placement of parts. One piece after another fit onto a skeleton meant to move like humans do. This early version moved on a body made to mimic human shape.

The robot structure includes:
Top area marked for where sensors go
Arm section with servo motors
Body section containing the microcontroller and electronic components

With this setup, the robot can make simple movements while engaging those who stop by.

3.8 System Testing

A first version got checked inside labs, also hallways - places where conditions stayed fixed. A number of trials took place so the team could check how well the system worked

- Sensor detection accuracy
- Voice output clarity
- Servo motor movement stability
- Display message visibility
- Continuous system operation

Far off, the machine checked guests to see if it could spot them. Sometimes close, sometimes not, its sensing skill faced trial after trial. Distance shifted each round, just to be sure.

3.9 Performance Evaluation

Performance of the system got checked using these factors:

Detection	accuracy
Response	time
Interaction	quality
System	reliability
Power	consumption

When tested indoors, performance stayed strong. Interaction with guests remained steady throughout.

4.PROJECT DEFINITION

The scope of this project is to develop a humanoid robot that can automatically detect visitors and greet them using sensors and embedded systems. The robot uses a microcontroller, ultrasonic or IR sensors, a voice module, and servo motors to interact with people. It can display welcome messages on an LED display and produce voice greetings through a speaker. The system is designed to be simple, low-cost, and suitable for places such as colleges, hospitals, and offices. The project mainly focuses on automated guest interaction and reducing human effort. In the future, the system can be upgraded by adding technologies like artificial intelligence, face recognition, and voice recognition.

5.SCOPE OF PROJECT

Aiming to build a humanlike robot capable of spotting guests without help, this effort leans on sensor tech and built-in electronics. Instead of relying on complex networks, it runs via a small computer board teamed with motion detectors like ultrasonic or infrared units. Greetings come alive through sound chips linked to speakers, while moving parts allow gestures. Messages appear on a light-based screen each time someone arrives. Simplicity drives the design, keeping expenses low so schools, clinics, or workspaces can use it easily. One main goal here is cutting down manual work through automatic responses to visitors. Later on, features such as voice detection, facial scanning, or smart decision-making systems might get included.

6.PRINCIPLE

A signal starts things when someone comes close - sensed by either ultrasonic or infrared hardware. This input travels straight to the ESP32 chip, which acts like the brain here. Once it receives that data, parts begin moving one after another. A short audio clip begins playing from the speaker without delay. At nearly the same time, words appear on

screen in clear letters. Movement follows as small motors shift position slowly. Each piece reacts only when needed. Meanwhile, tiny electric motors move the hands or head in basic ways, making it seem alive. Because of this, the machine notices people arriving and says hello by itself.

7.CONSTRUCTION

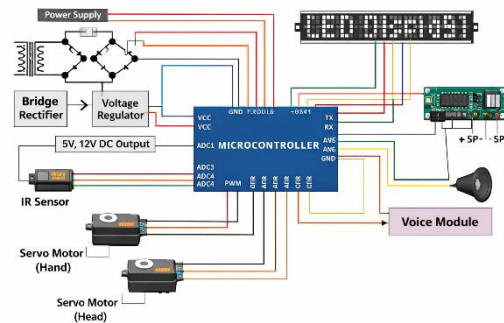

From the start, building the sensor-driven humanoid robot means linking up several key parts: power source, brain chip, detectors, movement units, and signal senders. Power comes through a transformer that lowers voltage, then passes into a bridge rectifier changing AC to DC. After that, a voltage regulator ensures smooth delivery of steady current across circuits. At the core sits the microcontroller - this piece runs everything by coordinating each attached element. Detection happens when an infrared sensor picks up someone standing close to the machine. One servo motor handles the robot's head motion, while another takes care of how the arms move. As someone approaches, the system triggers a spoken greeting through a built-in speaker. Messages also appear at the same time on a small screen fixed to the front. Built into the body structure, every piece works together without needing help once set up. The whole setup stands on two legs, ready to sense and respond whenever someone comes near.

8.CONSTRUCTION DETAILS

A) ESP-32 MICROCONTROLLER

A tiny computer runs everything this setup needs. From sensor messages, decisions happen right away. When info comes in, motion follows - motors turn, lights show patterns, sound plays out loud.

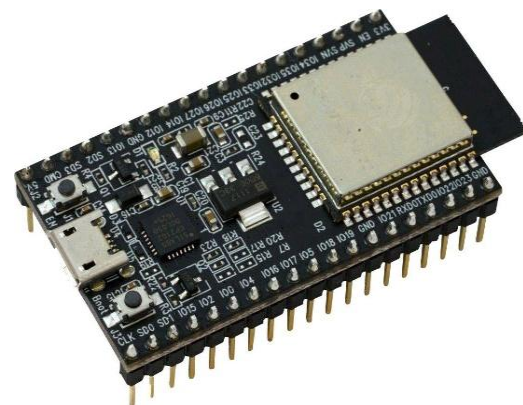

B) IR SENSOR MODULE



A small infrared device notices if someone stands close to the machine. As soon as a guest enters its detection zone, it passes a message to the main chip - someone has shown up.

C) SERVO MOTOR MODULE



Fitted with small electric motors, the robot moves like a person. Its hand shifts position thanks to one of these motors, while a second handles how the head turns. Because it can move this way, people feel like they're partaking in real interaction when saying hello.

D) LED DISPLAY MODULE



Messages appear on the screen when someone arrives. Connected to a small computer, it lights up words like hello or welcome. Light joins sound so people understand better. What shows depends on signals sent by the main circuit.

9. WORKING

A visitor steps into view, triggering the robot's awareness through sensors. Instead of waiting, it reacts right away with motions meant to greet. Either an infrared or ultrasonic device keeps watch without pause around its space. Once someone enters that invisible zone, a message zips from sensor to brain unit. This tiny computer reads the alert, then wakes up parts built to respond. Sound follows quickly - a recorded phrase spills from the speaker. At the same time, words glow on screen in friendly letters. Meanwhile, servo motors adjust the robot's head or arm to mimic natural movements. Because of this setup, it senses guests on arrival and offers a greeting all by itself.

10. ADVANTAGES

Now imagine a robot shaped like a person helping guests automatically. Without needing breaks, it keeps going day and night. Each visitor hears the same clear welcome message. Built with basic electronics, it does not drain budgets or require complex setup. Sounds, screens, and body motions make talking to it feel natural. Not needing extra staff saves ongoing expenses.

11. APPLICATIONS

A robot shaped like a person fits well in various public spots. In schools for higher education, one greets newcomers instead of staff. Medical centers place it near entrances so people find their way while getting simple answers. Businesses set it up at front desks where it handles check ins without help. Places such as stores with many shops, overnight stays, money services, shows with displays, and gatherings out in the open let it talk to those passing by.

12. RESULT

A test version of a human-shaped robot managed to spot visitors automatically, then react. Starting when sensors picked up people nearby, it would trigger a spoken hello from the audio unit. Messages popped up plainly on the light screen while small motor-driven motions added subtle motion. Without pause, it ran inside for hours, showing steady results throughout. From first try onward, operation stayed smooth and consistent.

13. CONCLUSION

From embedded tech came a human-shaped machine that senses its surroundings. When someone arrives, it notices right away - then speaks, shows words on screen, moves its arms to say hello. Built around smart circuits, the device takes over repetitive tasks without tiring. Instead of people doing greetings all day, this one handles it nonstop. Sensors feed data, tiny controllers respond fast - it works like clockwork. Efficiency rises when machines take routine jobs off our hands.

14. FUTURE SCOPE

Better tech could boost how the machine works. Voice detection, spotting faces, along with smart learning systems might help it think sharper. Hooking it up to online networks opens doors for distant checks plus fresh info uploads. Smarter responses come easier when it talks with guests using these upgrades.

15. REFERENCES

- [1] I. Skubis, A. Mesjasz-Lech, and J. Nowakowska-Grunt, "Humanoid Robots in Tourism and Hospitality-Exploring Managerial, Ethical, and Societal Challenges," *Applied Sciences*, vol. 14, no. 24, p. 11823, 2024.
- [2] B. Obrenovic, X. Gu, G. Wang, D. Godinic, and I. Jakhongirov, "Generative AI and human-robot interaction: implications and future agenda for business, society and ethics," *AI & society*, vol. 40, no. 2, pp. 677-690, 2025.
- [3] M. S. Amin, S. T. H. Rizvi, and M. M. Hossain, "A comparative review on applications of different sensors for sign language recognition," *Journal of Imaging*, vol. 8, no. 4, p. 98, 2022.

[4] S. Oruma, R. Colomo-Palacios, and V. Gkioulos, "Architectural views for social robots in public spaces: business, system, and security strategies," *International Journal of Information Security*, vol. 24, no. 1, p. 12, 2025.

[5] A. Cruces, A. Jerez, J. P. Bandera, and A. Bandera, "Socially assistive robots in smart environments to attend elderly people-a survey," *Applied Sciences*, vol. 14, no. 12, p. 5287, 2024.

[6] I. Skubis, "Exploring the potential and perceptions of social robots in tourism and hospitality: insights from industry executives and technology evaluation," *International Journal of Social Robotics*, vol. 17, no. 1, pp. 59-72, 2025.

[7] S. Gupta, S. Modgil, C.-K. Lee, M. Cho, and Y. Park, "Artificial intelligence enabled robots for stay experience in the hospitality industry in a smart city," *Industrial Management & Data Systems*, vol. 122, no. 10, pp. 2331-2350, 2022.

[8] S. Capy et al., "Yokobo: a robot to strengthen links amongst users with non-verbal behaviours," *Machines*, vol. 10, no. 8, p. 708, 2022, doi: <https://doi.org/10.3390/machines10080708>.

[9] C. Qin, A. Song, L. Wei, and Y. Zhao, "A multimodal domestic service robot interaction system for people with declined abilities to express themselves," *Intelligent Service Robotics*, vol. 16, no. 3, pp. 373-392, 2023.

[10] F. Palermo et al., "Advancements in Context Recognition for Edge Devices and Smart Eyewear: Sensors and Applications," *IEEE Access*, 2025.

