

IOT-Enabled Smart Grid Monitoring With Solar Energy Integration

¹M. V. Shruthi, ²D. Neha, ³P. Vaignika Reddy, ⁴C. Aishwarya

¹Assistant Professor, ²Student, ³Student, ⁴Student

¹Electrical and Electronics Engineering,

¹Stanley College of Engineering and Technology for Women, Hyderabad, India

¹venkatashruthi@stanley.edu.in, ²nehadarla709@gmail.com, ³vaignikareddy85@gmail.com,
⁴aishwaryaraju1413

Abstract—This project introduces a smart grid system that uses IoT technology to monitor power usage and works with solar energy to help manage electricity in a more efficient and eco-friendly way. The system checks electrical data and how much solar power is being produced right now, helping users see how much energy they're using and how much comes from renewable sources. Using IoT, the data gathered can be watched and studied from a distance, which helps people understand how much power is being used and make smarter choices to use energy more efficiently. The new system helps save energy, makes the power system more dependable, and uses solar energy in the best possible way. Right now, it's especially important because energy use is going up and using more renewable energy is key for long-term growth. Besides offering real-time monitoring, the system helps with smart energy use and supports moving towards more efficient and eco-friendly power systems. In the future, the system could be made better by adding automatic control methods, better ways to store energy, and techniques that use data to guess how much energy will be needed and make the system work better. The suggested method helps with managing energy in a sustainable way by encouraging the use of renewable energy sources and making better use of electricity.

Index Terms—IoT, Smart Grid Monitoring, Solar Energy Integration, Renewable Energy, Energy Management, Power Monitoring, Real-Time Monitoring, Sustainable Power Systems.

I. INTRODUCTION

The fast rise in electricity use and the growing worries about the environment from traditional power sources have made it very important to develop energy systems that are both sustainable and efficient. Traditional power grids mostly rely on fossil fuels, which cause pollution and are not available in large amounts. Because of this, adding renewable energy like solar power to current electrical systems is a key part of creating long-term, sustainable energy options [9]. Solar energy is a clean, renewable, and plentiful type of power that helps cut down on the need for traditional energy sources. In recent years, the idea of smart grids has become a modern approach to making electrical power systems more efficient, reliable, and easier to monitor [2], [10]. A smart grid uses modern technology to track electrical information and control the flow of energy in a better way.

Using IoT technology with smart grids allows for real-time tracking of power generation and use, and helps understand how energy is being used [1], [5]. Internet of Things allows people to monitor systems from a distance, gather data, and see how well the system is working. This helps users understand how to use energy better and make smart choices. Using solar energy along with IoT monitoring systems makes smart grids better by giving real-time data on how much renewable energy is being produced and how much power is being used [4]. These systems let users see how much solar energy is made and how well it is being used in the system. This helps people be more aware of their energy use, cuts down on unnecessary power use, and supports better management of energy resources.

This project is about creating and setting up a smart grid monitoring system that uses the internet of things and includes solar power integration. The system is designed to track important electrical measurements and show the data to users as it happens. Using renewable energy along with IoT technology helps make energy use more efficient, allows for better tracking, and encourages the use of sustainable energy methods [3], [4]. The project also shows how smart monitoring systems can be really helpful in building the energy networks of the future. Using IoT technology in energy systems adds a new kind of smartness and automatic control to how power is watched and managed. IoT systems allow for constant gathering of electrical information like voltage, current, and power consumption, which can then be sent to distant platforms for analysis and display [1]. This feature lets users and operators check how well the power system is working from any location, which makes it easier to see what's happening and manage the system better. Real-time monitoring can help spot unusual problems, stop system breakdowns, and make the whole system more dependable [3].

Using renewable energy along with smart monitoring systems is becoming more important for today's power networks. Solar energy is one of the most common renewable resources and can help produce clean and sustainable electricity [9]. It's important to keep track of and manage solar power production and use well in order to get the most out of it. Smart grid monitoring systems look at how energy moves through the system and help make sure that energy from renewable sources is used in a good way. Smart grid technologies help with better planning and more efficient use of energy [2]. By looking at how energy is used and produced, we can better manage the demand for energy and cut down on wasted energy [6]. These systems also promote the use of renewable energy technologies in homes, businesses, and industries by making it easier to see how much energy is being used.

The new smart grid system that uses IoT and solar power shows how modern communication tools can improve the way energy is managed. The system allows users to track their energy use as it happens, access data from a distance, and analyze it effectively, which helps them gain a clearer understanding of how they use energy and promotes the use of eco-friendly energy options [1], [4]. These systems help create better, cleaner, and more efficient power networks for the future. Another key benefit of combining IoT with smart grids is that it helps make energy use more clear and increases people's understanding of how energy is used. Traditional

power systems usually don't have clear details about how much energy is being used and produced, which makes it hard for people to see how electricity is being used. Using IoT-based monitoring systems, real-time data about electrical measurements and solar energy production can be gathered and shown on digital platforms [5].

This helps users monitor how much energy they use and make smarter choices to save energy. Smart grid monitoring systems also help make the electrical network more stable and dependable. Keeping an eye on system settings helps find problems like voltage changes, too much power use, or not using power well before they get worse [3]. By catching these problems early on, we can take the right steps to stop the system from breaking and keep the power network running well. This helps the system work better and lowers the cost of keeping it running. Adding solar power and other clean energy sources to smart grids helps the world cut down on carbon emissions and pollution [9]. Solar energy is good for the environment and can be found in many places, so it works well as a replacement for the usual way of making energy from fossil fuels. Using solar energy along with smart monitoring helps make the most of renewable power and keeps the electricity system running smoothly. Also, IoT-enabled monitoring systems can help make future smart energy systems better.

As the need for electricity increases and more renewable energy sources are used, today's power systems need better ways to monitor and control them [4]. IoT technology helps build smart energy systems that can automatically look at energy usage, make the best use of power, and make the whole system work better [1], [5]. Creating a smart grid monitoring system that uses IoT and includes solar power is a key move in updating how we manage energy systems. By using renewable energy technologies along with smart monitoring tools, the system helps increase energy efficiency, makes the energy supply more dependable, and encourages the use of sustainable energy methods [2], [9]. This project shows how combining IoT and renewable energy can lead to better and more efficient power systems for the future. Besides that, the fast growth of digital technologies has changed how electrical power systems are watched over and controlled [10].

Traditional ways of checking power usage usually involve people watching manually and don't give up-to-date info on how the system is working. This limitation makes it hard to spot inefficiencies and act quickly when there are problems with power. Using IoT technology in smart grid systems helps solve these problems by allowing automatic data gathering, constant system tracking, and the ability to access information from a distance [1], [3]. This allows users and system operators to get clear information about how much energy is being produced and used. Another key feature of IoT-enabled monitoring systems is that they help make decisions based on real data. By looking at electrical data over time, the system can give useful insights into how energy is used and how the system works. This information can help make energy planning better, use resources more efficiently, and lower unwanted power loss [6]. This ability is especially helpful in systems that use renewable energy, because the amount of energy produced can change based on things like weather and time of day [9]. Using solar energy along with smart monitoring tools helps create local energy systems that are not dependent on a central source. In old power systems, electricity is made at big power plants and sent far away to people who use it [1], [4]. However, renewable energy sources like solar panels let energy be made right where it's needed, closer to where people use it.

IoT-based monitoring systems help manage this distributed generation by giving real-time updates on how much energy is being produced and how well the system is working [1], [4]. This makes managing energy locally more efficient and makes the entire power system more dependable. Smart grid monitoring systems can help make energy use more sustainable in homes, businesses, and factories [2]. By giving clear details about how much energy is used and how much comes from renewable sources, these systems help people learn how to use energy more wisely. When people are more aware of how much energy they use, they tend to use less electricity, which helps cut down on expenses and also makes less harm to the environment [5], [9]. The increasing use of smart technologies in power systems helps in building smarter cities in the future [10]. Smart energy systems are important parts of today's city setups, and managing energy efficiently helps make sure cities grow in a way that is good for the environment [2]. Smart monitoring systems that use the Internet of Things help manage energy sources in a smart way, making sure there is a steady supply of electricity and reducing wasted energy [1].

Putting IoT technology together with solar energy-based smart grid monitoring systems is a strong way to better manage energy and make things more sustainable [4], [9]. These systems help improve the performance, dependability, and eco-friendliness of today's power networks by allowing real-time tracking, distant access, and smart analysis of electrical data [1], [3]. This project shows how these technologies can be used in real situations and points out how they might help create smarter energy systems in the future.

II. SURVEY OF LITERATURE

In recent years, combining renewable energy sources with smart monitoring technology has become a big topic of interest. Scientists have looked into different ways to make energy use better, track it more effectively, and save more energy by using IoT and smart grid systems [1], [4]. A lot of research has been done on using IoT in smart grids to allow for real-time tracking and management of electricity related measurements. IoT-based monitoring systems let you keep track of voltage, current, and how much power is being used all the time, using sensors and small computer chips that are connected [3], [5]. These systems let people access energy data from a distance, so they can look at how much electricity they're using and make smarter choices to manage their energy use more effectively. These technologies also help find problems, make the system work better, and save energy [6]. Scientists have also looked into how adding renewable energy sources affects today's power networks.

Solar energy has become very popular because it is clean, widely available, and good for the environment [9]. Several studies show that combining solar power with smart monitoring systems can make energy use more efficient and decrease the need for traditional power sources that rely on fossil fuels [4], [9]. Solar energy systems work along with monitoring tools to help users keep an eye on how much energy is being produced and make the best use of it. Recent advances in IoT technology have improved smart grid systems by allowing remote monitoring through cloud platforms and mobile apps [1]. These platforms let you see energy data as it happens and help manage the system better. Some studies have suggested using IoT to create solar monitoring systems that give detailed information on how much solar energy is being produced and how well the system is working [3]. These systems help people see how much renewable energy is used to meet the electricity needs.

Besides that, scientists have looked into smart ways to control systems in smart grids to make the power distribution better and keep the system running smoothly [2], [6]. Smart monitoring systems can detect unusual situations like voltage changes, too much electricity use, and odd power usage. Finding these issues early helps keep electrical equipment safe and makes sure the power

system works well [3]. Combining IoT technology with renewable energy systems is shown in the literature to be a good way to handle modern energy management [1], [4]. IoT-enabled monitoring systems collect data in real time, allow access from a distance, and offer better analysis of energy use, helping to use power more efficiently and support the growth of sustainable energy. These studies show how important it is to create smart monitoring systems that connect renewable energy sources with smart grid technology. Many researchers have highlighted the value of combining smart monitoring tools with renewable energy systems to make power generation and delivery more efficient. Smart grid technologies enable better communication between different parts of the power system so they can share information instantly [2], [10]. This helps energy generation, storage, and usage work together better, leading to more dependable and effective energy handling.

Research on IoT-based energy monitoring systems shows that using sensors and microcontrollers allows for precise measurement of electrical factors like voltage, current, and power [3], [5]. These parameters are sent via wireless networks to cloud platforms, where they can be looked at and shown in a visual way [1]. This ability to monitor in real time lets users keep an eye on how the system is working all the time and spot any problems early before they cause big failures [3]. Scientists have also looked into solar energy tracking systems that use internet of things platforms to check how well solar panels are working [4], [9]. These systems let users check how much solar power is being made, track how energy moves around, and see how well the whole system is working. Using solar power along with smart tracking tools helps make it simpler to handle energy resources and use renewable energy in the best possible way [9]. Another key area of study looks at ways to manage energy more effectively in smart grid systems [6].

Good energy management helps keep the energy supply and demand in balance and cuts down on extra power use [6]. Smart devices connected to the internet help collect important information that can be used to understand how energy is being used and to make smarter ways to control it [1], [5]. These methods make the system work better and lower the cost of running it. Several studies have also shown how IoT helps improve the reliability of power systems and detect faults more effectively [3]. Keeping an eye on electrical values all the time helps find issues like too much load, changes in voltage, or problems with the equipment early on. Finding problems early lets you fix them fast, which keeps the system running smoothly and stops electrical devices from getting damaged. Moreover, IoT-based smart grid systems help in developing distributed energy resources, where energy is made at many places using renewable sources [4], [9]. Using IoT technology makes it simpler to monitor these spread-out energy sources because it gives you one place to access all the system information [1]. This helps to better match the production of renewable energy with how much electricity people use.

The research shows that combining IoT technology with solar power and smart grids is a good way to manage energy more effectively in today's world [1], [4]. These technologies allow for instant monitoring, better control of systems, and more effective use of renewable energy sources [2], [9]. Studies in this area show how important it is to create smart monitoring systems that help keep power grids both sustainable and dependable [10].

III. EXISTING SYSTEM

In traditional electrical power systems, monitoring and managing how much energy is used are usually done with old methods that don't offer real-time tracking or smart control features [2], [10]. Most current power systems rely mostly on generating electricity from traditional energy sources like coal, oil, and natural gas. These energy sources are not endless and cause a lot of pollution and carbon emissions [9].

Traditional power monitoring systems usually give just simple details about how much electricity is being used, either through people checking the meters by hand or using basic measuring tools. These systems don't provide detailed information about real-time electrical factors like voltage, current, and how much power is being used [3]. Because of this, people usually don't know much about how much energy they use, which can cause them to use energy in a less efficient way and waste more power than needed.

Another problem with current systems is that they don't connect well with renewable energy sources [4], [9]. Even though more people are setting up solar energy systems, many old ways of checking how well they work don't offer good tools to track how much solar power is being made and how much it adds to the total energy used. If there are no good ways to check on the system, it's hard to tell how well it's working and make the most of renewable energy.

Besides that, regular systems usually don't allow for remote monitoring or automatic data analysis [1]. Users need to be there in person to check how the system is working or find any problems, which can make it take longer to fix the issues. The absence of remote access makes managing the system less efficient and creates more difficulties when fixing problems.

Besides that, old power systems usually don't have smart ways to find and handle problems. Strange problems like voltage changes, too much power use, or poor electricity sharing can happen without anyone noticing until they lead to big system issues. This can cause equipment to break, make repairs more expensive, and make the system less dependable [3].

Because of these limits, there is an increasing demand for better monitoring systems that can give up-to-date information, allow control from a distance, and help manage energy more effectively [1], [4]. Using IoT technology along with renewable energy sources like solar power can provide a good way to fix the problems of traditional power monitoring systems [4], [9].

IV. PROPOSED SYSTEM

The system suggested is a smart grid monitoring setup that uses the Internet of Things and includes solar energy integration, which helps enhance energy tracking, improve efficiency, and support sustainable power management [1], [4]. The system uses renewable energy sources along with modern IoT technology to track electrical performance and show real-time data on how much power is being used and how much solar energy is being generated [1], [9]. The system suggests using solar energy as a clean power source to help meet the electricity needs. The system keeps checking key electrical measurements like voltage, current, and total power usage all the time [3]. These parameters are gathered and handled by a microcontroller-based monitoring unit, which helps in precisely measuring and studying how well the system is working. Using IoT technology, the data gathered can be sent to a digital platform where it can be seen and studied as it happens [1]. This lets users check the power system's performance from a distance and learn about how energy is being used. Real-time monitoring helps people understand their energy use better and makes it easier for them to make smart choices that use energy more efficiently [5].

Another key part of the proposed system is its smart way of monitoring and managing the system. By keeping an eye on electrical settings, the system can spot problems like changes in voltage or using too much power [3]. This helps keep the system running

reliably and prevents electrical equipment from getting damaged. Using solar energy along with smart monitoring helps make the most of renewable energy resources in a more efficient way [4], [9]. It helps manage energy production and use more effectively while lowering reliance on traditional power sources. The system also helps promote green energy by supporting the use of clean and renewable sources. An intelligent energy management system that uses IoT technology and includes solar power integration provides a modern approach to monitoring and managing the smart grid [2]. The system helps make monitoring more accurate, allows people to access energy data from a distance, and encourages better use of renewable energy, which works well in homes, schools, and factories.

The new system improves upon traditional power monitoring systems by offering constant and automatic tracking of electrical measurements [1], [3]. Unlike traditional methods that depend on people watching manually, this new system gathers information instantly and lets people check it from a distance. This lets users keep an eye on how well the solar power system is working and look into how energy is being used in a better way. The system also helps manage energy better by offering clearer insight into how electricity is made and used in the system. By keeping track of how much solar energy is generated and how much electricity is being used, users can see how much renewable energy is helping to meet their power needs. This makes it easier to use solar energy more efficiently and lessens the need for regular electricity from the power grid. Another key benefit of the proposed system is that it helps make power systems more dependable and work better. Constantly checking helps find problems like sudden changes in voltage, using too much power, or strange system actions [3]. Finding these issues early can stop problems from happening and keep electrical equipment working safely.

The system also helps by supporting the use of clean energy in a way that makes the most of renewable sources. Solar energy is good for the environment and can be found in many places, which makes it a great choice for creating clean electricity [9]. By using solar energy along with IoT monitoring technology, the system helps use energy more efficiently and helps cut down on environmental harm. The system also allows for easy updates and improvements in the future. Using advanced tools like automatic load control, energy storage solutions, and smart data analysis can help make the system work better. These changes can help create better smart energy systems that can automatically handle energy production and use [4].

The suggested smart grid system that uses IoT and includes solar power offers an effective, dependable, and eco-friendly way to manage energy in today's world [1], [4]. By using renewable energy sources along with real-time tracking and the ability to access the system from a distance, the system shows how smart technology can help make electrical power systems more efficient and environmentally friendly [2], [9].

V. METHODOLOGY AND COMPONENTS

The new smart grid system uses IoT and solar power to track electrical conditions and manage how electricity is distributed [1], [4]. The system gathers data from the solar power setup as it happens, uses a small computer to handle the information, and then shares it with a phone app so you can check on it [1]. The system starts with the solar panel, which turns sunlight into electricity as direct current power [9]. This generated power goes through a diode, which stops the current from flowing back from the battery to the solar panel. The energy is saved in a 12V rechargeable battery, which works as a place to keep the energy and provides power when there isn't enough sunlight or when the sun isn't shining.

A voltage sensor checks the voltage of the solar panel or battery, and the ACS712 current sensor measures the electricity flowing through the system [3]. These sensors keep gathering electrical measurements and pass the information to the ESP32 microcontroller. The ESP32 (NodeMCU) takes in data from the sensors and figures out key electrical values like voltage, current, and power. The ESP32 uses its built-in Wi-Fi to send the data it collects to a mobile app made with MIT App Inventor, allowing users to watch the system's performance as it happens [1], [5]. To manage load control and protect the system, a relay driver circuit is used. This circuit includes a BC547 transistor and a resistor to control a 12-volt relay. The relay functions like a switch that connects the inverter to the load. The microcontroller can switch the relay on or off automatically based on the conditions it is monitoring, which helps control the electricity going to the load [2].

The electricity stored in the battery is sent to the inverter, which changes the direct current into alternating current that can power home devices and other equipment that uses AC. The air conditioner uses the converted power and works as it should. This approach lets us keep track of solar power being produced and how much electricity is being used all the time, and it also lets us watch over and manage everything from a distance using IoT technology [1], [4].

Functional Flow Diagram

Solar Panel → Diode → Battery → Sensors (Voltage & ACS712 Current Sensor) → ESP32 Microcontroller → Relay Driver → Relay → Inverter → AC Load → MIT App (Monitoring & Control)

Components Used

1. Solar Panel (12V): Changes sunlight into electricity, which is stored as direct current power.
2. Diode (1N4007): Prevents the battery from sending electricity back to the solar panel.
3. Battery (12V Li-ion): Stores the electrical energy made by the solar panel so it can be used later.
4. Voltage Sensor: Checks the electricity level from the solar panel or battery.
5. Current Sensor (ACS712): Measures the amount of electricity passing through the load or system.
6. ESP32 (NodeMCU) Microcontroller: The system takes in data from sensors and sends that information to the IoT platform through a Wi-Fi connection.
7. Relay Driver (BC547 + Resistor): Boosts the control signal from the microcontroller to power the relay.
8. Relay (12V): Serves as a switch that is controlled by electricity to manage the flow of power to the connected device.
9. Inverter: Changes the stored direct current power from the battery into alternating current power.
10. AC Load: Shows the electrical device or appliance that is powered by the system.
11. MIT App: A mobile app that helps track system settings and allows you to manage the system from a distance using the Internet of Things.

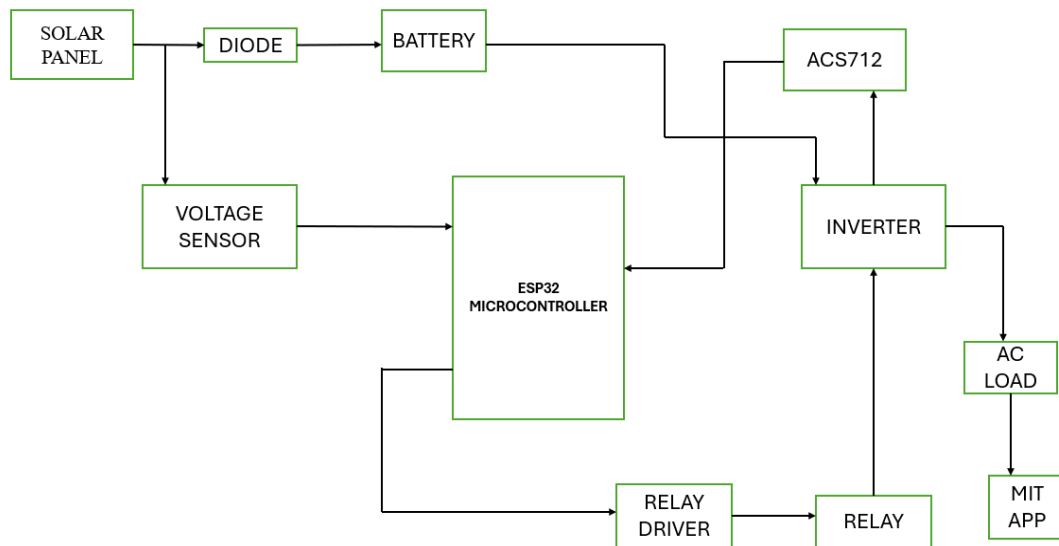

Fig.1: Block Diagram of Solar Integrated IoT Monitoring and Control System

Components Used and Described:

5.1 Solar Panel (12V)

The solar panel is the main source of energy in the system and uses the photovoltaic effect to turn sunlight into electricity [9]. When sunlight hits the semiconductor material in the panel, it creates direct current (DC) electricity. The electricity made from direct current is used to charge the battery and provide power to the monitoring system. A 12V solar panel is often used in small renewable energy projects because it gives enough power to charge 12V batteries and run low-power electronics. Solar panels are good for the environment and help decrease the need for traditional energy sources.

5.2 Diode (1N4007)

The 1N4007 diode is used to protect the solar charging circuit. Its main job is to stop the electricity from flowing back from the battery to the solar panel. At night or when there is not much sunlight, the voltage from the solar panel becomes lower than the voltage of the battery. If there's no diode, the energy stored in the battery might go back into the solar panel, leading to energy waste and possible harm. The diode lets electricity move only one way, which helps charge things better and keeps the system safe.

5.3 Battery (12V Li-ion)

The battery stores energy in the system. It saves the electricity made by the solar panel when there is sunlight and uses that stored energy to provide power when there is no sunlight, like at night or on cloudy days. Lithium-ion batteries are commonly used because they can store a lot of energy in a small space, last longer, charge quicker, and need less maintenance than older types of batteries. The energy stored in the battery is later used to provide power to the inverter and the monitoring system.

5.4 Voltage Sensor

The voltage sensor measures how much electricity is in the solar panel or battery. It works by lowering the input voltage through a voltage divider circuit, so that it can be safely read by the microcontroller. The sensor sends the voltage measurement to the ESP32 microcontroller so it can be watched and studied [3]. Checking the voltage is important because it helps find issues like low voltage, high voltage, or how the battery is charging, which makes sure the power system works safely.

5.5 Current Sensor (ACS712)

The ACS712 current sensor is used to measure how much current is passing through the system or the load [3]. It works by using the Hall Effect, which senses the magnetic field created when electricity flows through a material. The sensor gives out a voltage that is related to the current it measures, and the microcontroller reads that voltage. This information is used to figure out how much power is being used and to check how well the system is working. It's important to keep track of the current to spot when there's too much load and to use energy in a good way.

5.6 ESP32 (NodeMCU) Microcontroller

The ESP32 microcontroller serves as the main brain and control center of the system [1]. It checks the voltage and current from the sensors and uses that information to figure out things like how much power is being used and what the system is doing. The ESP32 comes with Wi-Fi built in, so it can send data to a phone app or a cloud service as it happens. It also manages the relay to control the power going to the load. Because of its fast processing speed, ability to connect wirelessly, and many input and output pins, ESP32 is commonly used in IoT projects.

5.7 Relay Driver (BC547 + Resistor)

The relay driver circuit uses a BC547 transistor along with a base resistor. The ESP32 microcontroller sends out a low-power signal that isn't strong enough to directly power the relay coil. So, the transistor works like an amplifier, which helps increase the current needed to turn on the relay. The resistor controls the amount of current going to the transistor's base to keep it from getting damaged. This circuit makes sure the relay switches properly and keeps the microcontroller safe from large electric currents.

5.8 Relay (12V)

The relay is a switch that uses electricity to control how the inverter connects to the load [2]. When the microcontroller sends a signal through the relay driver circuit, the relay coil receives power and switches the position of the relay. This lets the system

switch the load on or off by itself based on how the system is doing. Relays are often used in automation systems because they help separate the control circuit from the high-power load circuit electrically.

5.9 Inverter

The inverter takes the direct current power from the battery and changes it into alternating current power, which is needed to run home appliances. Most electrical gadgets like lights, fans, and other small devices use alternating current, which is called AC. The inverter does the job of converting DC to AC and gives a steady AC power to the connected device. In renewable energy setups, the inverter is important because it allows the energy stored in batteries to power devices that need alternating current.

5.10 AC Load

The AC load is the electrical device or appliance that is powered by the system. Examples are things like LED lights, fans, chargers, or other small devices used at home. The load gets AC power from the inverter and uses electrical energy to work. Keeping an eye on the current and how much power is being used helps understand how well the system is working and makes sure energy is used in a smart way.

5.11 MIT App (MIT App Inventor)

The MIT App is a mobile app created with MIT App Inventor that offers an easy-to-use way to check on the system [1], [5]. The app gets data from the ESP32 using Wi-Fi and shows information like voltage, current, and the system's condition. Users can watch how well the solar power system is working as it happens and check how much energy is being used from a distance. This IoT monitoring feature makes it easier to access the system, control it, and manage energy use.

5.12 Connecting Terminals, Wires, and Enclosure

Connecting the terminals and wires makes sure that all parts of the system, like the solar panel, battery, inverter, and sensors, have the right electrical connections. Using wires that are properly rated ensures safe electricity flow, lowers energy loss, and stops wires from getting too hot. Strong terminals help keep connections tight and stop problems.

A container or carrying case is used to keep all parts safe from dust, wetness, and physical harm. It also makes things safer by stopping accidental touches with live parts and helps the system stay small and easy to take along for use outside or in hard-to-reach areas.

NORMAL OPERATION (SOLAR POWER AVAILABLE)

When there is enough sunlight, the solar panel changes solar energy into direct current electricity [9]. This generated power is controlled and used to charge the battery at the same time as it powers the system. During this situation, the relay helps control how energy flows and lets the system use solar power directly when it's available [2]. This helps use renewable energy in a good way and keeps the system working smoothly [4].

LOW OR NO SOLAR POWER (NIGHT OR CLOUDY CONDITIONS)

Low or no solar power happens when there is not enough sunlight, like at night or when it is cloudy. When there is not enough sunlight or during the night, the solar panel does not produce enough electricity. In these cases, the battery becomes the main source of energy. The electricity stored in the battery is sent to the inverter, which changes it into alternating current (AC) so that it can power the connected devices. At the same time, the DC regulator keeps giving a steady DC output to charge mobile devices or other low-power electronics. This makes sure the power keeps flowing even when there's no sunlight [9].

RESTORATION OF SOLAR POWER

When the sun comes out again, the solar panel starts making electricity again and begins to charge the battery. At the same time, the system begins using solar energy directly to power the connected devices. The relay automatically switches the system back to using solar power, which lowers how much stored battery energy is used [2]. This automatic switching helps keep the battery charged and makes sure energy is used wisely for later use [4].

VI. RESULTS AND DISCUSSION

The suggested IoT-enabled smart grid monitoring system with solar integration was effectively constructed and put into operation, showcasing efficient real-time electrical parameter monitoring and renewable energy use [1], [4]. According to the mobile application, which shows roughly 220V and 1A, the system measured voltage and current levels accurately, showing that the sensor and data transmission components were operating as intended [3]. By integrating solar panels with the battery and inverter system, the load could be supported by renewable energy, lowering reliance on traditional grid power [9]. Through the Android application created with MIT App Inventor, customers were able to remotely monitor system performance thanks to the IoT module's wireless connection capabilities [1], [5]. The transformer, battery pack, microprocessor, and sensors were among the hardware elements that functioned dependably, and the LED indications verified active system status.

The system's discussion reveals that although the prototype offers enough real-time monitoring, sensor limits and calibration problems may cause slight variations in data [3].

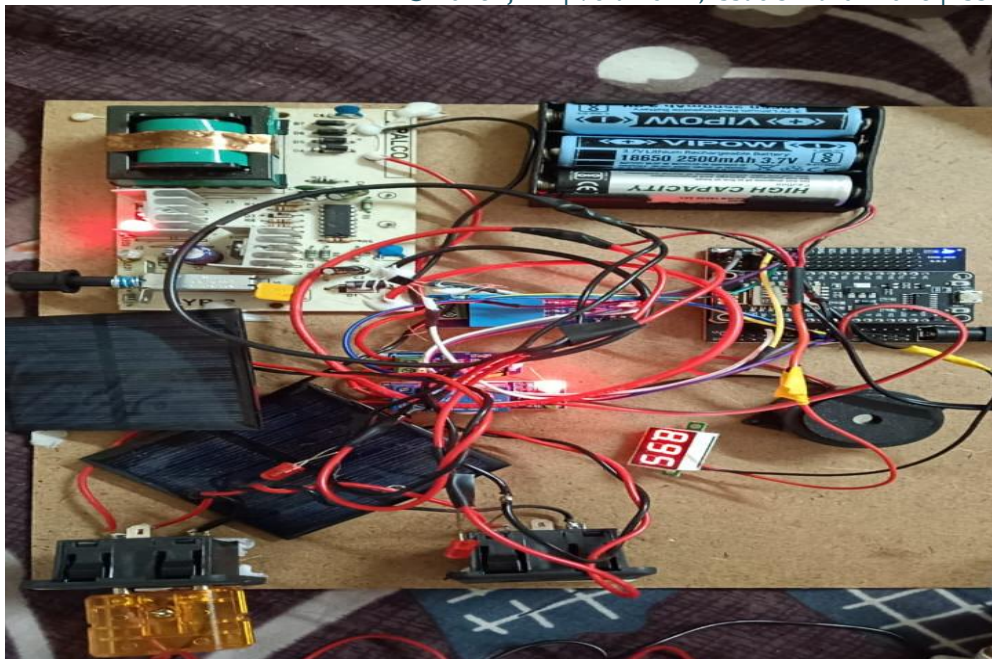

Fig. 2: IoT-enabled smart grid monitoring system hardware configuration with solar integration.

Under ideal operating conditions, the system demonstrates dependability, especially when solar input is available and the battery is sufficiently charged [4], [9]. Remote monitoring, which enables users to monitor energy consumption and make well-informed decisions for optimal energy use, is one of the system's main benefits [1], [5]. Nevertheless, the existing model's shortcomings include its inability to handle large loads, its lack of sophisticated automation, and its reliance on simple or manual control techniques [2]. Long-term stability and safety may also be impacted by the wiring configuration.



Fig. 3: Real-time voltage and current monitoring is displayed on the mobile application interface.

Automatic load switching, sophisticated energy storage management, machine learning-based predictive analytics integration, and better hardware design utilizing PCBs and protective enclosures are some examples of potential future advancements [4], [6]. Overall, by fusing IoT technology with solar energy, the system shows a workable approach to sustainable energy management, helping to create dependable, effective, and environmentally friendly power systems [1], [9].

VII. CONCLUSION

An effective and sustainable approach to energy management is effectively demonstrated by the IoT-enabled smart grid monitoring system with solar integration. In order to provide remote access and control, the system may monitor important electrical characteristics like voltage and current in real time and send the data to a mobile application. The initiative encourages the use of renewable resources, lessens reliance on traditional power sources, and improves overall energy efficiency by integrating solar energy with the grid system [9]. By enabling ongoing monitoring, better decision-making, and more efficient use of available energy, the deployment of IoT technology offers substantial value [1].

Even though the system was created as a prototype and has several drawbacks, like a small load capacity and simple control methods, it offers a solid basis for further developments [2]. The system can be expanded for practical uses with additional improvements including automation, sophisticated data analytics, and better hardware design. In general, the project supports the shift to smart grid technologies and sustainable energy solutions by advancing the development of intelligent, dependable, and environmentally friendly power systems.

VIII. ACKNOWLEDGMENT

The authors would like to sincerely thank their faculty advisor and mentors for their invaluable advice, encouragement, and support during the research. Additionally, they express gratitude to the laboratory personnel for offering the technical support and resources required during the design and implementation stages. Lastly, the writers thank their peers for their encouragement and helpful criticism, which enhanced the caliber of this work.

REFERENCES

- [1] A. Ghasempour, "Internet of Things in Smart Grid: Architecture, Applications, Services, Key Technologies, and Challenges," *Inventions*, vol. 4, no. 1, pp. 1–12, 2019.
- [2] V. C. Gungor et al., "Smart Grid Technologies: Communication Technologies and Standards," *IEEE Transactions on Industrial Informatics*, vol. 7, no. 4, pp. 529–539, Nov. 2011.
- [3] S. S. Reddy and P. R. Bijwe, "Real-Time Monitoring of Smart Grid Using IoT," *International Journal of Electrical Power & Energy Systems*, vol. 104, pp. 530–539, 2019.
- [4] M. A. Hannan, M. Faisal, P. J. Ker, R. A. Begum, and A. Hussain, "Review of Internet of Energy Based Smart Grid Technology," *Renewable and Sustainable Energy Reviews*, vol. 112, pp. 822–839, 2019.
- [5] S. Madakam, R. Ramaswamy, and S. Tripathi, "Internet of Things (IoT): A Literature Review," *Journal of Computer and Communications*, vol. 3, no. 5, pp. 164–173, 2015.
- [6] T. Logenthiran, D. Srinivasan, and T. Z. Shun, "Demand Side Management in Smart Grid Using Heuristic Optimization," *IEEE Transactions on Smart Grid*, vol. 3, no. 3, pp. 1244–1252, 2012.
- [7] N. Kumar, S. Zeadally, and J. J. P. C. Rodrigues, "Vehicular Delay-Tolerant Networks for Smart Grid Data Management Using Mobile Edge Computing," *IEEE Communications Magazine*, vol. 54, no. 10, pp. 60–66, 2016.
- [8] A. A. Khan, M. H. Rehmani, and A. Rachedi, "Cognitive-Radio-Based Internet of Things: Applications, Architectures, Spectrum Related Functionalities, and Future Research Directions," *IEEE Wireless Communications*, vol. 24, no. 3, pp. 17–25, 2017.
- [9] B. Parida, S. Iniyar, and R. Goic, "A Review of Solar Photovoltaic Technologies," *Renewable and Sustainable Energy Reviews*, vol. 15, no. 3, pp. 1625–1636, 2011.
- [10] H. Farhangi, "The Path of the Smart Grid," *IEEE Power and Energy Magazine*, vol. 8, no. 1, pp. 18–28, Jan.–Feb. 2010.