

Solar Powered Wireless Charging Station

Chaitnya Jadhav¹, Pranav Jadhav², Rahul Mali³, Mahesh Sanadi⁴, Shreyash Patil⁵,
¹²³⁴⁵Diploma In Electrical Engineering, Sanjay Bhokare Group Of Institute Miraj, Maharashtra, India
⁶Prof. P. V. Patil, Dept. of Electrical Engineering, SBGI Miraj, Maharashtra, India

Abstract - The increasing demand for portable electronic devices and the depletion of conventional energy resources have created a need for sustainable and efficient charging solutions. This project, "Solar Powered Wireless Charging Station," aims to design and develop an eco-friendly charging system that utilizes solar energy to wirelessly charge electronic devices.

The system consists of a solar panel, charge controller, rechargeable battery, DC-DC converter, and a wireless power transmission module based on electromagnetic induction. Solar energy is captured by the solar panel and stored in a battery, which supplies power to the wireless charging circuit. The transmitter coil generates an alternating magnetic field, which induces voltage in the receiver coil of the device, enabling wireless charging without physical connectors.

1. INTRODUCTION

This project provides a system that is easy to understand and also to operate, a system that would be cheap and affordable, reliable and easy to maintain the system of remote control and offers long durability. It adds more comfort to everyday living by removing the inconvenience of having to move around to operate a fan regulator.

Using this circuit, you can change the speed of the fan from your couch or bed. Infrared receiver module TSOP1738 is used to receive the infrared signal transmitted by remote control.

The circuit is powered by regulated 9V. The AC mains is stepped down by transformer X1 to deliver a secondary output of 12V-0-12V. The transformer output is rectified by full-wave rectifier comprising diodes D1 and D2, filtered by capacitor C9 and regulated by 7809 regulator to provide 9V regulated output.

1.1 Sub Heading 1

The proposed system is a solar powered wireless charging station that uses renewable energy for charging electronic devices. The system is designed to reduce the use of conventional electricity and promote green energy. In this system, a solar panel is used to convert sunlight into electrical energy. This energy is stored in a battery with the help of a charge controller. The stored energy is then supplied to a wireless charging transmitter circuit. The transmitter generates an electromagnetic field which transfers energy

wirelessly to the receiver coil of the device. Thus, the system provides a safe, efficient, and wire-free method of charging mobile phones and other electronic devices.

1.2 Sub Heading 2

The system includes solar panel, charge controller, battery, and wireless charging module. The solar panel generates electricity from sunlight and stores it in the battery. The transmitter coil creates a magnetic field which induces current in the receiver coil. This current is used to charge the device wirelessly.

2. HEADING 2

This section describes the overall design of the system using a block diagram. It shows the flow of energy from solar panel to battery and then to the wireless charging module. The NodeMCU is used for IoT-based monitoring of system parameters like battery level and charging status. The design ensures efficient energy utilization and smooth wireless power transfer.

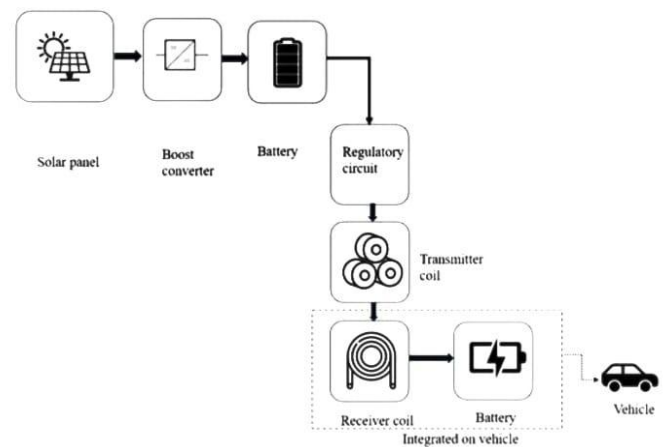

Fig –1: Simple Block Diagram Of Solar Powered Wireless Charging Station

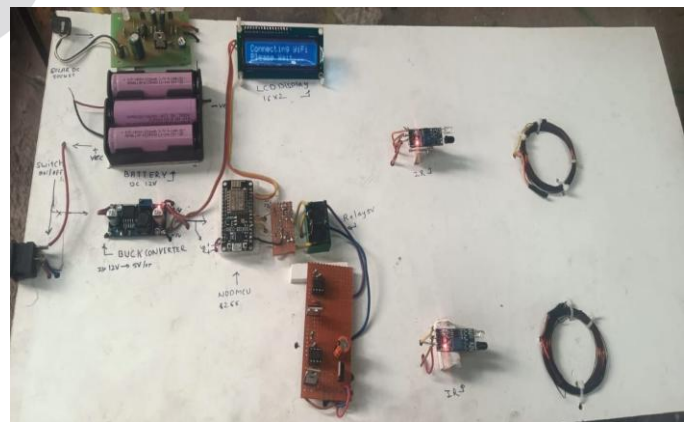

Fig -2: Solar Powered Wireless Charging Station

This project is a solar powered wireless charging station integrated with IoT technology. The solar panel charges a 12V battery, and a buck converter is used to step down voltage to 5V for the system. A NodeMCU (ESP8266) is used for WiFi connectivity and monitoring, and a 16x2 LCD displays system status. The wireless charging module uses transmitter and

receiver coils to transfer power without wires. IR sensors and relay are used to control the charging process automatically. Thus, the system provides smart, efficient, and eco-friendly wireless charging.

IoT technology makes the system smart by enabling real-time monitoring and control. Users can check charging status, battery level, and system performance remotely through internet connectivity.

3. CONCLUSIONS

The solar powered wireless charging station is an eco-friendly and efficient system.

It uses solar energy to generate electricity and reduce dependency on conventional power sources.

The system provides wireless charging, making it convenient and safe to use.

It is suitable for public places like bus stops, colleges, and rural areas.

Thus, this project promotes renewable energy and modern wireless technology.

ACKNOWLEDGEMENT

We would like to express our sincere gratitude to our project guide for their valuable guidance and support.

We also thank our institute and all those who helped us in completing this project successfully.

System Components & Their Functions

Sr. No.	Component	Function
1	Solar Panel	Sunlight converts into electrical energy
2	Charge Controller	Controls voltage & protect battery
3	Battery	Stores electrical Energy
4	Wireless Transmitter	Converts energy - electromagnetic field
5	Wireless Receiver	Receives energy from transmitter
6	Device	Charges EV, Electronic devices

REFERENCES

- [1] Abhijith Nidmar, Chetan Chougala, Kumaraswamy G. Solar Based Wireless Charging, International Journal of Engineering Research & Technology NCRACES, 2019, ISSN: 2278-0181
- [2] Adel El-Shahat, ErhuvwuAyisire, Yan Wu, Electric Vehicles Wireless Power Transfer State-of-The-Art, Special Issue on Emerging and Renewable Energy: Generation and Automation, 2019.
- [3] Alsomali A.M., Alotaibi Ali F.B., Al-Awami T., Charging Strategy for Electric Vehicles Using Solar Energy, 2017
- [4] Chandra Mouli G.R., Bauer P., Zeman M.. System design for a solar powered electric vehicle charging station for workplaces, 2016.