

# Powergrid Failure Detection by the Variance of Voltage and Frequency

Dodlo Obulesu<sup>1</sup>, Dakka Kalyani<sup>2</sup>, Mitte Purna Chandra Kumar<sup>3</sup>, Kathi Sekhar<sup>4</sup>

<sup>1,2</sup>Department of Electrical & Electronics Engineering, G. Pulla Reddy Engineering College, India

**Abstract:** This project aims to design a system that detects power grid failures by continuously monitoring the variance in voltage and frequency levels. Any significant deviation from nominal voltage (230V/400V) and frequency (50Hz) indicates grid instability or potential faults. By analyzing these variations, the system can identify abnormal conditions and trigger alerts, helping to prevent large-scale blackouts and equipment damage.

**Key Word:** Power Grid Failures, Voltage, Frequency, Variance, Monitoring, Grid Instability, Faults, Alerts, Equipment Damage

## I. Introduction

The modern electrical power system is a highly complex and interconnected network that requires continuous monitoring and control to ensure reliable operation. One of the major challenges in power systems is the occurrence of grid failures due to abnormalities in key electrical parameters such as voltage and frequency. Variations from their nominal values, typically 230V/400V for voltage and 50Hz for frequency, indicate instability in the power grid and may lead to serious faults, equipment damage, or large-scale blackouts.

Traditional monitoring methods are often insufficient to detect these variations in real time, resulting in delayed response and increased risk to electrical infrastructure. Hence, there is a need for an efficient system that can continuously observe these parameters and identify abnormal conditions at an early stage.

This project presents a system for detecting power grid failures by monitoring the variance in voltage and frequency levels. The system utilizes sensors to measure electrical parameters and a microcontroller to process the data. By analyzing deviations from nominal values, the system can identify grid instability and fault conditions. When such conditions are detected, appropriate actions such as triggering alerts or disconnecting the load can be initiated.

The proposed system enhances the reliability and safety of power systems by enabling timely detection of faults and preventing potential damage to electrical equipment. It also contributes to improving the overall stability of the power grid through continuous monitoring and automated response mechanisms.

## II. Material And Methods

This experimental hardware-based study was carried out in the Department of Electrical & Electronics Engineering at G. Pulla Reddy Engineering College, Kurnool, India during the academic year 2025–2026. The system was developed and tested using embedded hardware components to detect power grid failures by monitoring voltage and frequency variations. The study focuses on identifying abnormal electrical conditions and triggering protective actions.

**Study Design:** Experimental hardware implementation of a power grid failure detection system based on voltage and frequency variance monitoring using a microcontroller.

**Study Location:** This study was conducted in the Electrical & Electronics Engineering laboratory at G. Pulla Reddy Engineering College, Kurnool, Andhra Pradesh, India.

**Study Duration:** Academic year 2025–2026.

**Sample Size:** Prototype-based system (single embedded hardware setup).

**System Design Consideration:** The system was designed to continuously monitor electrical parameters such as voltage and frequency and detect deviations from nominal values. The components were selected based on reliability, low cost, and compatibility with embedded system design. The design ensures real-time response to abnormal conditions and safe operation of electrical loads.

### Materials Used

- PIC16F73 Microcontroller
- Voltage sensing unit
- Frequency sensing unit (opto-coupler based)
- Regulated power supply
- Relay module (for circuit breaker control)
- 16×2 LCD display
- Crystal oscillator
- Potentiometer (for calibration)
- LED indicators

### System Configuration Method

The system consists of a PIC16F73 microcontroller interfaced with voltage and frequency sensing circuits. The analog signals obtained from sensors are processed by the microcontroller, which continuously monitors deviations from preset nominal values (230V/400V and 50Hz).

When the measured parameters exceed the predefined threshold limits, the microcontroller triggers a relay to disconnect the load, thereby preventing equipment damage. The system also provides visual alerts through an LCD display and LED indicators.

The system operates under varying voltage and frequency conditions to analyze performance. The detection mechanism is based on identifying significant deviations (variance) in electrical parameters, which indicate instability or fault conditions in the power grid.

### System Configuration

- **System A:** Voltage and frequency sensing unit for monitoring electrical parameters
- **System B:** PIC16F73 microcontroller-based processing and decision-making unit
- **System C:** Protection and control unit using relay and indicators for load management

### Procedure methodology

The system continuously acquires voltage and frequency measurements using appropriate sensing units interfaced with the PIC16F73 microcontroller. The acquired signals are processed to evaluate the electrical parameters and determine deviations from nominal values. The system analyzes the variance in voltage and frequency levels to identify abnormal operating conditions in the power grid.

The processed data is displayed locally on a 16×2 LCD module, providing real-time information about the system status. The system operates continuously to monitor grid conditions and ensure timely detection of instability or faults. Additionally, the system incorporates protection mechanisms to detect abnormal conditions such as overvoltage, undervoltage, and frequency variations. Upon detection of such conditions, the relay module is activated to disconnect the load or trip the circuit breaker, thereby preventing damage to electrical equipment and ensuring system safety. Furthermore, the system generates alerts through LCD display and LED indicators to notify the user about fault conditions. The continuous monitoring and automated response mechanism enhance the reliability and stability of the power grid by enabling early detection and mitigation of potential failures.

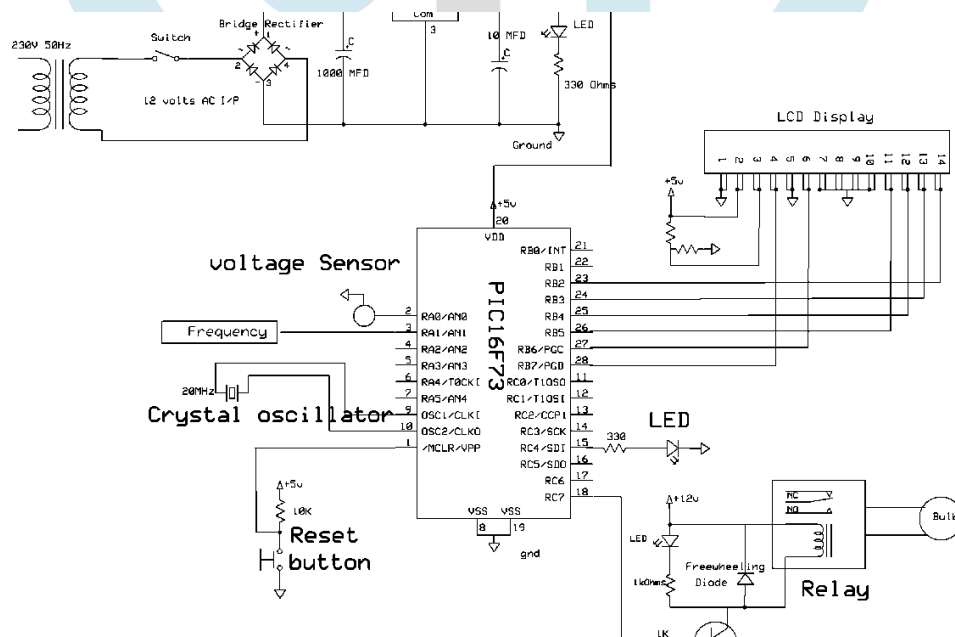

schematic diagram of Power Grid Failure detection based on sensing frequency or voltage variation

### Procedural steps for compilation, simulation and dumping:

#### Compilation and simulation steps:

For PIC microcontroller, PIC C compiler is used for compilation. The compilation steps are as follows:

- Open PIC C compiler.
- You will be prompted to choose a name for the new project, so create a separate folder where all the files of your project will be stored, choose a name and click save.

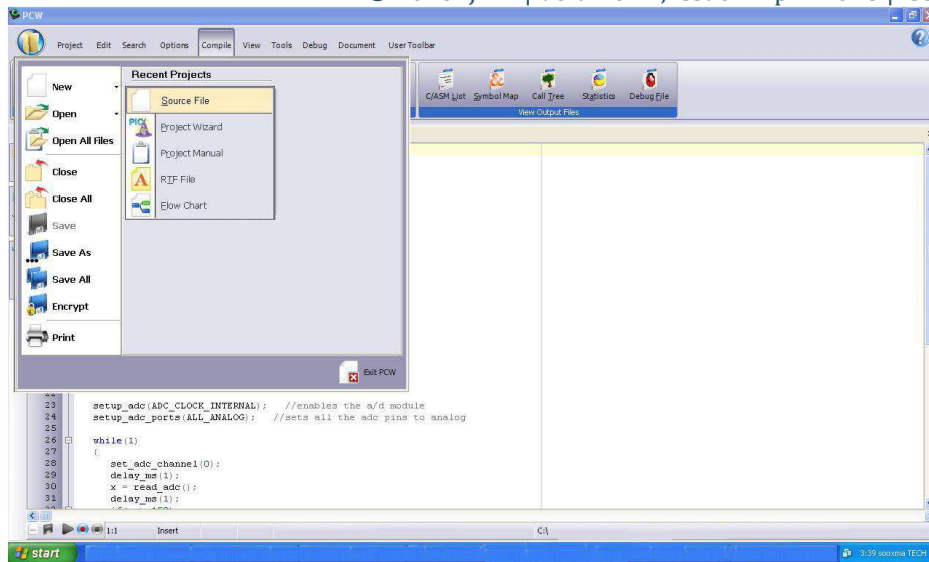

Picture of opening a new file using PIC C compiler

- Click Project, New, and something the box named 'Text1' is where your code should be written later.
- Now you have to click 'File, Save as' and choose a file name for your source code ending with the letter '.c'. You can name as 'project.c' for example and click save.
- Then you have to add this file to your project work.

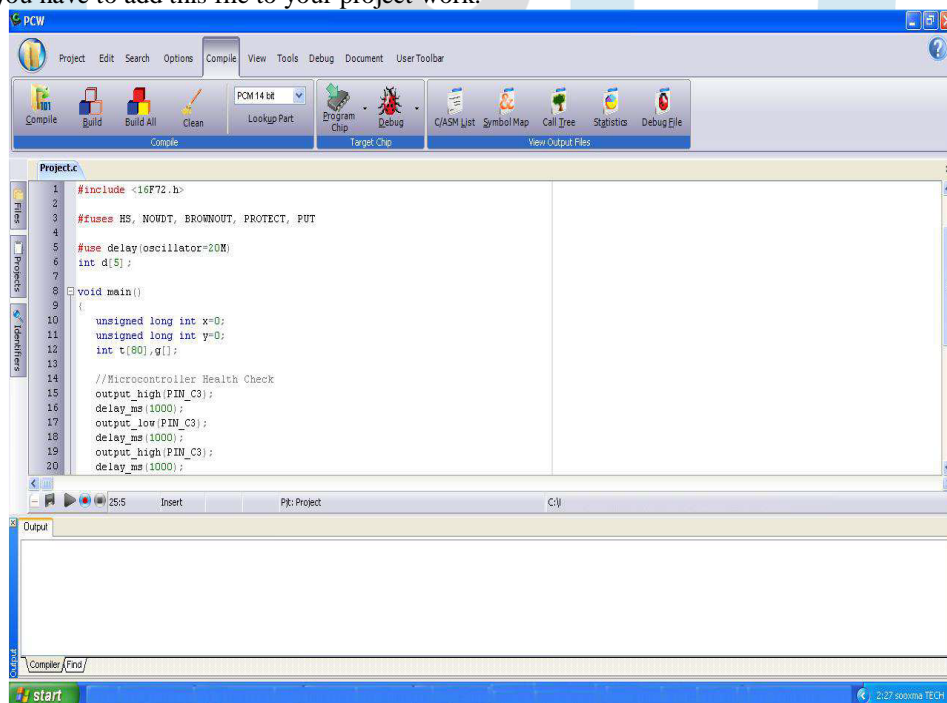

Picture of compiling a new file using PIC C compiler

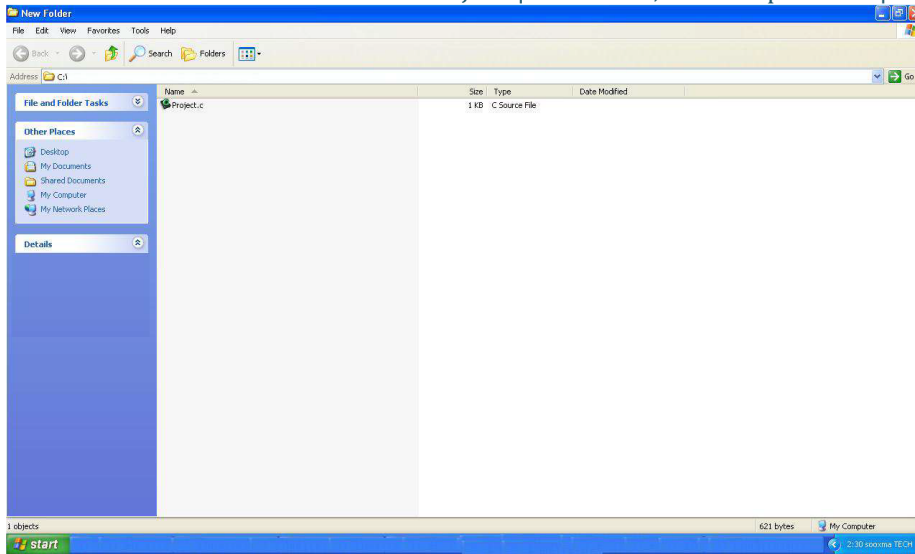

Picture of compiling a project.c file using PIC C compiler

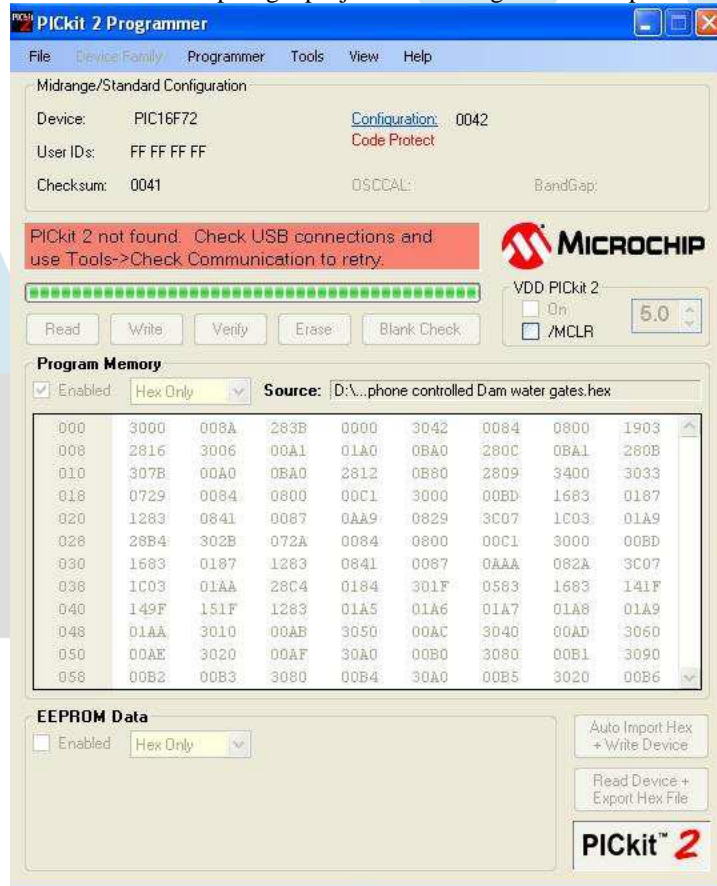

Picture of program dumper window

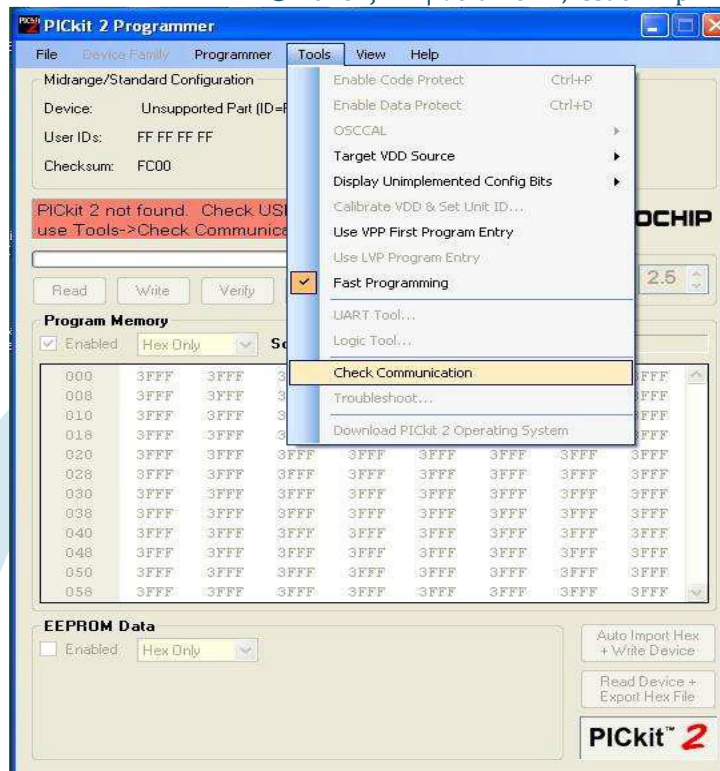

Picture of checking communications before dumping program into microcontroller

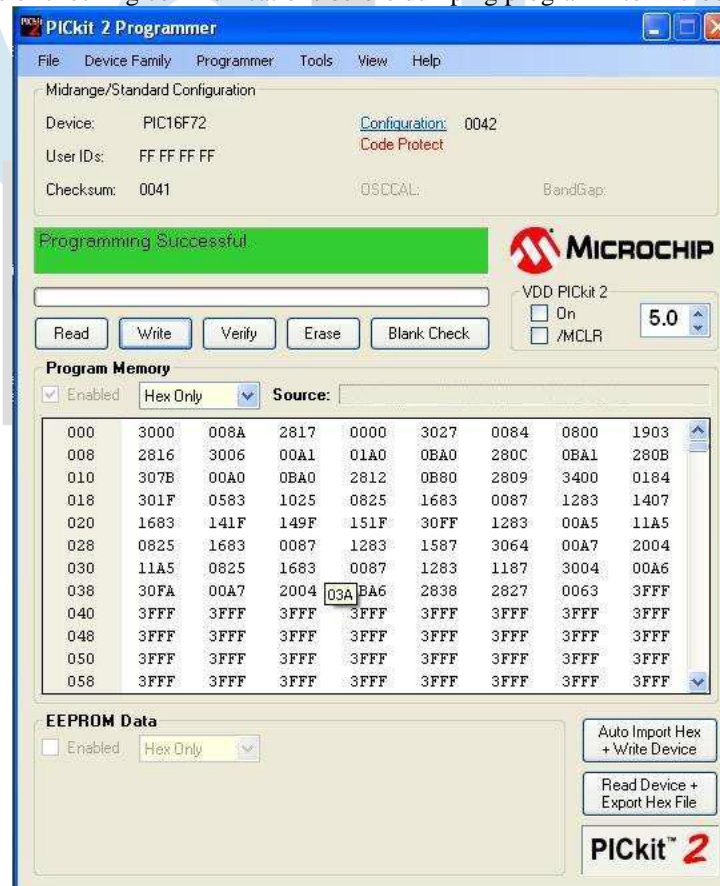

Picture after program dumped into the microcontroller

### III. Result

The developed power grid failure detection system successfully monitors electrical parameters such as voltage and frequency in real time. The measured values are continuously processed and accurately displayed on the 16x2 LCD module, providing clear information about the operating condition of the power system.

The system effectively detects deviations from nominal voltage (230V/400V) and frequency (50Hz), indicating grid instability or fault conditions. The results demonstrate consistent and reliable performance under varying input conditions, accurately identifying both normal and abnormal operating states.

Furthermore, the protection mechanism operates efficiently by activating the relay to disconnect the load during abnormal conditions such as overvoltage, undervoltage, and frequency variations. The response of the system is fast and ensures protection of connected equipment from potential damage.

Additionally, the alert system provides clear indications of fault conditions through LCD display and LED indicators. The overall system performance confirms its capability to detect grid failures accurately and enhance the safety and reliability of the power system.

#### IV. Discussion

The implementation of the power grid failure detection system demonstrates the effectiveness of using embedded systems for continuous monitoring of critical electrical parameters such as voltage and frequency. In comparison with conventional monitoring methods, the proposed system provides improved functionality through real-time detection of deviations and automatic response to abnormal grid conditions.

The use of the PIC16F73 microcontroller ensures reliable and stable processing of sensed data, enabling accurate identification of grid instability based on voltage and frequency variations. The system operates efficiently under different operating conditions and maintains consistent performance in detecting both normal and fault states.

Furthermore, the integration of sensing units and protection mechanisms enhances system safety by enabling immediate response to abnormal conditions. The relay-based control effectively disconnects the load during overvoltage, undervoltage, and frequency disturbances, thereby preventing potential damage to electrical equipment.

The proposed system is simple, cost-effective, and suitable for real-time applications in power system monitoring. It can be further extended for advanced applications such as integration with smart grid systems, remote monitoring using wireless communication, and incorporation of intelligent algorithms for predictive fault detection, thereby increasing its applicability in modern power system management.

#### V. Conclusion

The developed power grid failure detection system effectively monitors voltage and frequency variations to identify abnormal operating conditions in the power system. By continuously analyzing deviations from nominal values, the system is capable of detecting grid instability and potential faults in real time.

The implementation using the PIC16F73 microcontroller ensures reliable processing of sensor data and stable system performance under varying conditions. The integration of sensing units, display module, and relay-based protection mechanism enables automatic detection and response to abnormal conditions such as overvoltage, undervoltage, and frequency variations.

The system successfully demonstrates its ability to enhance the safety and reliability of electrical networks by preventing equipment damage and minimizing the risk of large-scale failures. The results confirm that the proposed approach is efficient, cost-effective, and suitable for real-time power system monitoring applications.

Furthermore, the system can be extended for advanced applications such as integration with smart grid technologies, remote monitoring systems, and intelligent fault prediction techniques, thereby increasing its applicability in modern power system management.

#### References

The sites which were used while doing this project:

- [www.wikipedia.com](http://www.wikipedia.com)
- [www.allaboutcircuits.com](http://www.allaboutcircuits.com)
- [www.microchip.com](http://www.microchip.com)
- [www.howstuffworks.com](http://www.howstuffworks.com)

#### Books referred

1. Raj kamal –Microcontrollers Architecture, Programming, Interfacing and System Design.
2. Mazidi and Mazidi –Embedded Systems.
3. PCB Design Tutorial –David.L.Jones.
4. PIC Microcontroller Manual – Microchip.
5. Pyroelectric Sensor Module- Murata.
6. Embedded C –Michael.J.Pont.