

# Development of an Efficient IoT-Integrated Arduino System for High-Performance Solar Energy Applications

**Pardhavi Sai Sree.T**

Assistant Professor

Electrical and Electronics Engineering

School of Engineering and Technology, Sri Padmavathi Mahila Visvavidyalayam, Tirupati

[pardhavi03@gmail.com](mailto:pardhavi03@gmail.com)

**Abstract**—the increasing demand for renewable energy has accelerated the adoption of solar power systems. However, conventional solar energy systems often suffer from inefficiencies due to lack of real-time monitoring and control. This paper presents the development of an efficient Internet of Things (IoT)-integrated Arduino-based system designed to enhance the performance of solar energy applications. The proposed system incorporates sensors to measure voltage, current, and temperature, and utilizes an Arduino microcontroller for data acquisition and processing. IoT technology enables real-time monitoring and remote access to system performance data through a cloud platform. Experimental results demonstrate improved efficiency, better energy utilization, and enhanced system reliability. The proposed approach offers a cost-effective and scalable solution for modern solar energy management systems.

**Key Words**—Solar Energy, Internet of Things (IoT), Arduino, Energy Efficiency, Renewable Energy, Real-Time Monitoring, High-Performance Systems.

## I. INTRODUCTION

Energy plays a vital role in the development of modern society, and the growing demand for electricity has created significant pressure on conventional energy resources. Fossil fuels, which have been the primary source of energy for decades, are not only limited in availability but also contribute to environmental pollution and climate change. As a result, there is an increasing shift toward renewable energy sources, among which solar energy is one of the most widely adopted due to its abundance, sustainability, and eco-friendly nature.

Solar energy systems, particularly photovoltaic (PV) systems, convert sunlight into electrical energy. Although these systems are widely used, their performance is often affected by various environmental and operational factors such as temperature variations, solar irradiance, dust accumulation, and load conditions. In many traditional setups, there is limited provision for continuous monitoring and control, which can lead to reduced efficiency, energy losses, and difficulty in identifying faults or performance issues.

With the advancement of modern technologies, the integration of smart systems into renewable energy applications has gained considerable attention. The Internet of Things (IoT) is one such technology that enables devices to communicate and share data over the internet in real time. By incorporating IoT into solar energy systems, it becomes possible to monitor system parameters continuously, analyse performance, and take timely actions to improve efficiency.

Arduino, a low-cost and user-friendly microcontroller platform, has become popular for developing embedded systems and automation projects. Its compatibility with various sensors and communication modules makes it suitable for implementing smart monitoring systems. When combined with IoT technology, Arduino can be effectively used to design systems that collect real-time data such as voltage, current, and temperature, and transmit it to cloud platforms for analysis and visualization.

In this context, the present study focuses on the development of an efficient IoT-integrated Arduino-based system for solar energy applications. The proposed system aims to provide real-time monitoring, improve energy utilization, and enhance overall system performance. By enabling remote access to system data, users can easily track energy generation and identify potential issues, thereby ensuring better management of solar resources.

The main objective of this work is to design and implement a cost-effective and reliable system that combines solar energy technology with IoT and embedded systems. The study also evaluates the performance of the proposed system under different conditions to demonstrate its effectiveness in improving efficiency and reliability.

## II. EXISTING SYSTEM

In traditional solar energy systems, the primary focus is on energy generation rather than monitoring and optimization. Most conventional systems operate independently without any real-time tracking of performance parameters such as voltage, current, or

temperature. The data, if recorded, is often collected manually or through basic display units, making it difficult to analyze system behavior over time. This lack of continuous monitoring leads to inefficiencies and reduced overall performance.

Existing solar setups generally do not incorporate advanced communication technologies. As a result, users are unable to access system data remotely or in real time. Any faults or performance issues, such as reduced output due to shading, dust accumulation, or temperature rise, often go unnoticed until they significantly impact the system. This delay in fault detection can result in energy loss and increased maintenance costs.

Some modern systems attempt to include digital monitoring, but they are often expensive and complex, limiting their use in small-scale or low-budget applications. These systems may require specialized hardware and software, making them less accessible for widespread adoption. Additionally, many of these solutions lack flexibility and are not easily scalable for different system sizes or user requirements.

Overall, the existing systems face several limitations, including lack of real-time monitoring, absence of remote accessibility, higher costs, and reduced efficiency. These challenges highlight the need for a cost-effective, smart, and easily deployable solution that can improve the performance and management of solar energy systems through modern technologies such as IoT and embedded systems.

### III. PROPOSED SYSTEM

The proposed system aims to develop an efficient and smart solar energy monitoring solution by integrating Arduino with Internet of Things (IoT) technology. Unlike traditional systems, this approach focuses not only on energy generation but also on real-time monitoring, analysis, and performance improvement. The system is designed to continuously collect important parameters such as voltage, current, and temperature from the solar panel and make this data available remotely through a cloud platform.

In this system, sensors are connected to the solar panel to measure electrical and environmental parameters. These sensors send data to the Arduino microcontroller, which processes the information and calculates key values such as power output. The Arduino acts as the central unit that manages data collection and prepares it for transmission. A Wi-Fi module (ESP8266) is used to connect the system to the internet, enabling communication with an IoT platform.

The collected data is transmitted to a cloud-based server, where it is stored and displayed in the form of graphs and charts. This allows users to monitor the performance of the solar system in real time using a web interface or mobile application. The system also helps in identifying performance issues such as low output or abnormal temperature, enabling timely corrective actions.

Overall, the proposed system provides a cost-effective, flexible, and scalable solution for solar energy monitoring. It improves system efficiency by enabling continuous observation and analysis, making it suitable for both small-scale and large-scale solar applications.

The proposed system offers several advantages over traditional solar energy systems. One of the main benefits is **real-time monitoring**, which allows users to continuously track system performance without the need for manual inspection. This helps in early detection of faults and reduces energy losses.

Another important advantage is **remote accessibility**. By using IoT technology, users can access system data from anywhere through the internet. This makes it easier to manage and monitor solar systems, especially in remote or inaccessible locations.

The system is also **cost-effective and easy to implement**. Arduino and IoT modules are affordable and widely available, making the system suitable for a wide range of users, including small-scale installations. In addition, the system is **flexible and scalable**, allowing it to be expanded or modified based on specific requirements.

Furthermore, the proposed system improves **energy efficiency and reliability** by providing accurate and continuous data. It supports better decision-making and maintenance planning, ultimately enhancing the overall performance and lifespan of the solar energy system.

### IV. HARDWARE AND SOFTWARE COMPONENTS

**Solar Panel:** The solar panel is the primary source of energy in the system. It converts sunlight into direct current (DC) electricity using photovoltaic cells. The amount of energy generated depends on environmental conditions such as sunlight intensity and temperature. This generated energy is supplied to the system and the connected load.

**Voltage Sensor:** The voltage sensor is used to measure the output voltage of the solar panel. Since the voltage produced by the panel may be higher than the safe limit of the Arduino, the sensor uses a voltage divider circuit to reduce it to a measurable level. The sensor provides an analog output, which is read by the Arduino for further processing.

**Current Sensor (ACS712):** The current sensor measures the flow of current from the solar panel to the load. It operates based on the Hall-effect principle and produces an analog signal proportional to the current. This measurement helps in calculating the total power generated and consumed in the system.

**Temperature Sensor (LM35):** The temperature sensor is used to measure the surrounding or panel temperature. It provides output in degrees Celsius, which helps in analyzing the effect of temperature on solar panel performance. Monitoring temperature is important because higher temperatures can reduce efficiency.

**Arduino UNO:** The Arduino UNO acts as the central controller of the system. It collects data from all sensors, processes the information, and performs calculations such as voltage, current, and power. It also manages communication with the Wi-Fi module to send data to the cloud.

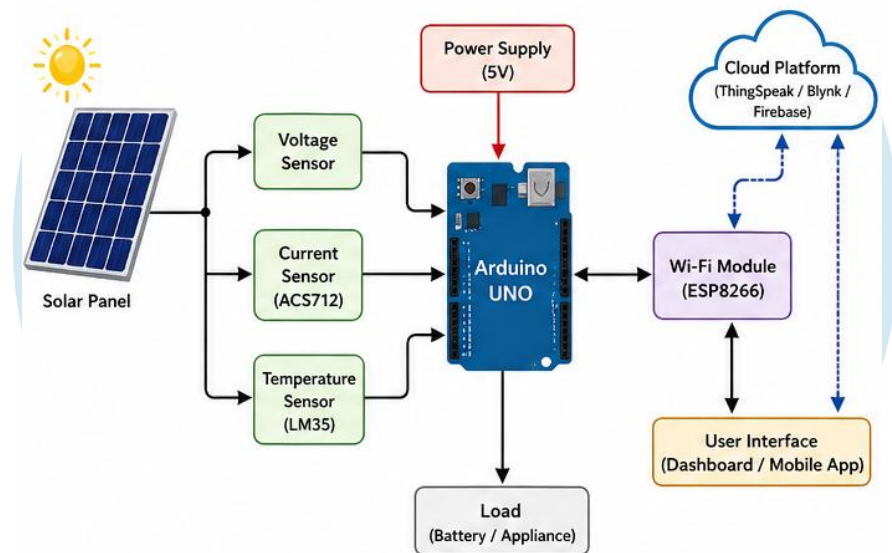

**Figure 1: Block Diagram**

**Power Supply (5V):** The power supply provides a stable 5V input required for the proper functioning of the Arduino and other components. A regulated power source ensures that the system operates reliably without fluctuations or damage to components.

**Wi-Fi Module (ESP8266):** The ESP8266 module enables internet connectivity in the system. It receives processed data from the Arduino and transmits it to a cloud platform. This allows remote monitoring of the solar system using IoT technology.

**Load (Battery / Appliance):** The load represents the device that consumes the energy generated by the solar panel. It can be a battery, light, or any electrical appliance. Monitoring the load helps in understanding energy usage and system efficiency.

**Arduino IDE:** The Arduino Integrated Development Environment (IDE) is used to write, compile, and upload the program to the Arduino board. It provides a simple platform for developing and testing the system's functionality.

**Embedded Program (Arduino Code):** The embedded program is written in C/C++ and controls the entire system operation. It reads sensor data, converts analog signals into digital values, calculates power, and sends the data to the Wi-Fi module. This program runs continuously to ensure real-time monitoring.

**Communication Protocols (HTTP/MQTT):** Communication protocols such as HTTP or MQTT are used to transfer data from the ESP8266 module to the cloud server. These protocols ensure reliable and efficient data transmission over the internet.

**Cloud Platform (ThingSpeak / Blynk / Firebase):** The cloud platform is used to store and analyze the data received from the system. It displays information in the form of graphs and charts, allowing users to monitor system performance easily.

**User Interface (Web / Mobile Application):** The user interface provides access to system data through a web dashboard or mobile application. Users can view real-time values of voltage, current, temperature, and power, which helps in monitoring and managing the solar energy system effectively.

## V.SYSTEM ARCHITECTURE

The proposed system architecture is designed to monitor solar energy generation and usage using an Arduino-based IoT framework. The system starts with a solar panel, which converts sunlight into direct current (DC) electrical energy, typically in the range of 12V to 24V. This generated energy is supplied to a load such as a battery or electrical appliance, while at the same time being monitored through multiple sensors. The architecture is structured to measure key electrical and environmental parameters, process them using a microcontroller, and transmit the data to a remote platform for analysis.

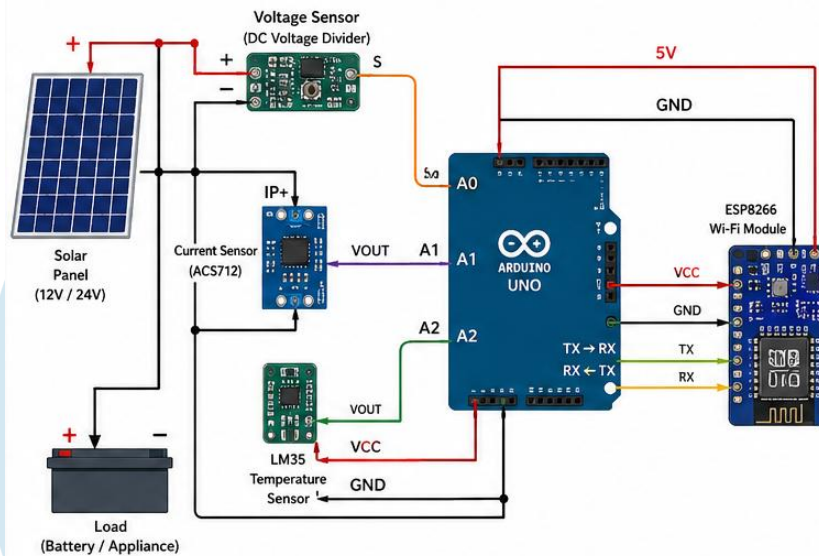

**Figure 2:** System Architecture

To measure the electrical output of the solar panel, a voltage sensor and a current sensor are used. The voltage sensor is connected across the solar panel terminals and works as a voltage divider to reduce the panel voltage to a safe level suitable for the Arduino. This scaled voltage is then fed into the analog input pin A0 of the Arduino. The current sensor (ACS712) is connected in series with the load to measure the current flowing through the circuit. It produces an analog output proportional to the current, which is connected to analog pin A1 of the Arduino. These two sensors together enable accurate calculation of electrical power generated by the solar panel.

In addition to electrical measurements, a temperature sensor (LM35) is included in the system to monitor environmental conditions. This sensor is connected to analog pin A2 of the Arduino and provides output in degrees Celsius. Since temperature has a direct impact on solar panel efficiency, this parameter is important for performance analysis. All sensor outputs are fed into the Arduino UNO, which acts as the central processing unit. The Arduino converts the analog signals into digital values using its built-in analog-to-digital converter and processes the data to determine parameters such as voltage, current, and power.

For communication, the system uses an ESP8266 Wi-Fi module, which enables the transmission of data over the internet. The module is connected to the Arduino through serial communication, where the transmit (TX) and receive (RX) pins are cross-connected to ensure proper data exchange. The Arduino is powered by a regulated 5V supply, while the ESP8266 operates at 3.3V. After processing the sensor data, the Arduino sends it to the Wi-Fi module, which transmits the data to a cloud platform for storage and visualization. This architecture ensures real-time monitoring, efficient data processing, and remote accessibility.

## VI.METHODOLOGY

The methodology of the proposed system is designed to ensure efficient monitoring and analysis of solar energy using an Arduino-based Internet of Things (IoT) framework. The overall process includes energy generation, parameter measurement, data processing, communication, and real-time monitoring. The structured approach enables accurate data acquisition and improved system performance.

**System Overview:** The proposed system integrates a solar panel, multiple sensors, an Arduino UNO microcontroller, and a Wi-Fi communication module. The solar panel generates electrical energy from sunlight, which is supplied to a load such as a battery or appliance. At the same time, the system continuously monitors important parameters to evaluate performance under varying environmental conditions. The collected data is processed and transmitted to a cloud platform for remote access.

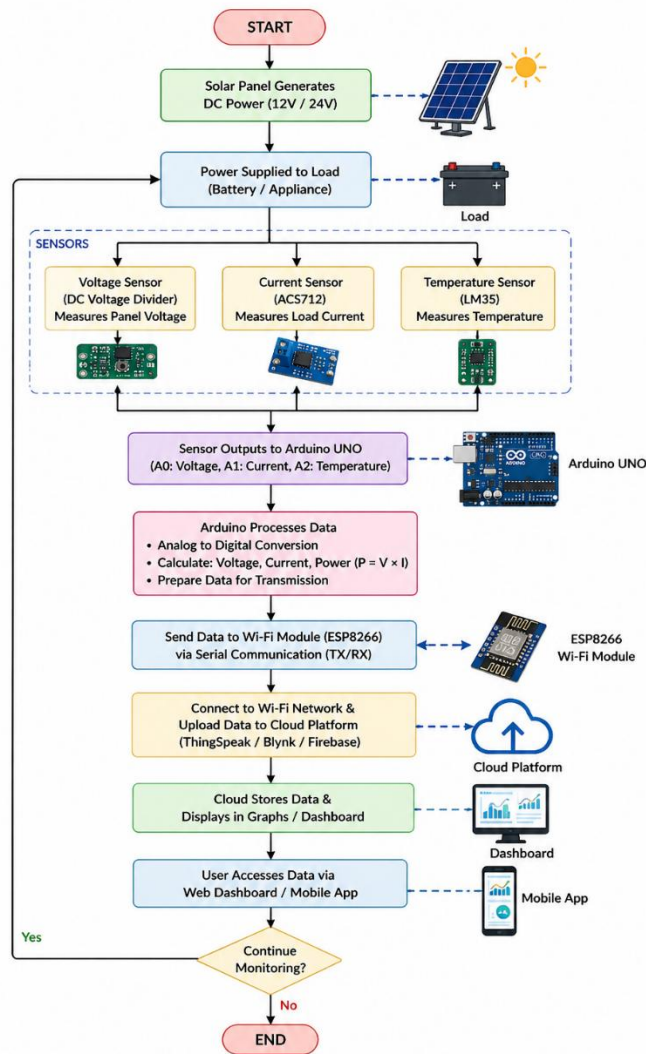

**Figure 3: Step-By-Step Process**

**Data Acquisition:** Data acquisition is carried out using sensors that measure electrical and environmental parameters. A voltage sensor is connected across the solar panel output to measure the generated voltage. Since the Arduino operates at a limited voltage range, the sensor reduces the panel voltage using a voltage divider circuit before sending it to the microcontroller. A current sensor (ACS712) is connected in series with the load to measure the current flowing through the system. Additionally, a temperature sensor (LM35) is used to monitor ambient or panel temperature. These sensors provide continuous analog signals corresponding to real-time system conditions.

**Data Processing:** The Arduino UNO serves as the central processing unit of the system. The analog signals from the sensors are connected to its analog input pins (A0 for voltage, A1 for current, and A2 for temperature). The Arduino converts these signals into digital values using its built-in analog-to-digital converter (ADC). It then processes the data to calculate key parameters such as voltage, current, and power output using standard mathematical relationships. This step ensures that raw sensor data is transformed into meaningful information for analysis.

**Data Transmission:** After processing, the data is transmitted to the ESP8266 Wi-Fi module through serial communication. The ESP8266 acts as a communication interface that connects the system to the internet. It uses communication protocols such as HTTP or MQTT to send data to a cloud-based platform. Proper voltage regulation is maintained, as the Arduino operates at 5V while the ESP8266 requires 3.3V. This stage enables seamless transfer of data from the local system to the cloud.

**Cloud Monitoring and Visualization:** The cloud platform stores and processes the transmitted data and presents it in the form of graphs, charts, and dashboards. This visualization allows users to analyze variations in voltage, current, temperature, and power over time. The platform provides remote accessibility through a web interface or mobile application, enabling users to monitor system performance from any location.

**Continuous Operation:** The entire system operates in a continuous loop to ensure real-time monitoring. Sensor data is collected at regular intervals, processed by the Arduino, and transmitted to the cloud without interruption. This continuous operation helps in detecting performance variations, identifying faults, and improving overall system efficiency. The integration of sensing, processing, and communication ensures reliable and efficient operation of the solar energy monitoring system.

## VII.SYSTEM WORKING

The working of the proposed IoT-integrated Arduino-based solar monitoring system is based on a continuous cycle of energy generation, data acquisition, processing, transmission, and visualization. The system begins its operation when the solar panel is exposed to sunlight and starts generating direct current (DC) electrical energy. This generated energy is supplied to the connected load, such as a battery or electrical appliance, while the system simultaneously monitors key parameters to evaluate performance.

Initially, the voltage sensor measures the output voltage of the solar panel. Since the panel may produce higher voltage levels, the sensor reduces it to a safe range suitable for the Arduino microcontroller. At the same time, the current sensor (ACS712) measures the flow of current from the solar panel to the load by producing an analog signal proportional to the current value. In addition, the temperature sensor (LM35) continuously measures the ambient or panel temperature, which is an important factor affecting solar efficiency.

The analog signals from all sensors are fed into the Arduino UNO through its analog input pins. The Arduino converts these analog signals into digital values using its internal analog-to-digital converter (ADC). It then processes the data to calculate essential parameters such as voltage, current, and power output using standard mathematical relationships. This processing step ensures that the system provides meaningful and accurate performance data.

Once the data is processed, it is transmitted to the ESP8266 Wi-Fi module via serial communication. The Wi-Fi module connects to a wireless network and sends the data to a cloud platform using internet communication protocols such as HTTP or MQTT. The cloud platform receives and stores the data, presenting it in the form of graphs and dashboards for easy visualization.

Users can access the system data remotely through a web interface or mobile application. This enables real-time monitoring of solar energy generation and system conditions from any location. The system operates continuously in a loop, ensuring that updated data is regularly collected, processed, and transmitted. This continuous monitoring helps in identifying performance variations, detecting faults, and improving overall system efficiency.

## VIII.RESULTS AND DISCUSSION

The performance of the proposed IoT-integrated Arduino-based solar monitoring system was evaluated under real-time operating conditions and compared with a conventional solar energy system. The comparison focuses on key parameters such as monitoring capability, data accessibility, efficiency, cost, and overall performance. The results demonstrate that the proposed system significantly improves monitoring accuracy, accessibility, and system efficiency.

The results clearly indicate that the proposed system provides significant improvements over the existing conventional solar systems. One of the major advantages is the ability to perform real-time monitoring of voltage, current, and temperature, which allows users to track system performance continuously. In contrast, the existing system lacks automation and depends on manual observation, which often leads to inefficiencies and delayed fault detection.

Another important improvement is remote accessibility. The proposed system uses IoT technology to send data to a cloud platform, enabling users to monitor the system from any location using a web or mobile interface. This feature is not available in traditional systems, where data is restricted to local displays or manual records. The availability of graphical data visualization in the proposed system also makes it easier to analyze trends and identify performance variations.

**Table 1:** Performance Comparison between Conventional and IoT-Based Solar Monitoring Systems

S. No.	Parameter	Existing System (Conventional Solar Monitoring System)	Proposed System (IoT-Integrated Arduino Solar Monitoring System)
1	Monitoring Type	Manual or limited	Real-time automatic monitoring
2	Data Accessibility	Local access only	Remote access via IoT (anywhere, anytime)
3	Fault Detection	Delayed and difficult	Immediate detection with real-time alerts
4	Efficiency	Lower due to lack of tracking	Higher due to continuous monitoring
5	Data Visualization	Minimal or no graphical representation	Graphs and dashboards on cloud platform
6	Technology Used	Basic electrical system	Arduino + Sensors + IoT (ESP8266)
7	Cost	High (for advanced systems)	Low and cost-effective
8	Scalability	Limited	Easily scalable and flexible
9	Maintenance	Manual and time-consuming	Reduced effort with smart monitoring
10	Data Storage	Not available or manual logging	Automatic cloud storage

In terms of efficiency, the proposed system performs better because continuous monitoring helps in identifying issues such as low output or abnormal temperature conditions at an early stage. This allows timely corrective actions, reducing energy losses.

Additionally, the use of low-cost components such as Arduino and ESP8266 makes the system economically viable, especially for small-scale applications.

Overall, the discussion highlights that the proposed IoT-integrated system is more efficient, reliable, and user-friendly compared to the existing system. It provides a modern solution for solar energy monitoring by combining sensing, processing, and communication technologies, making it suitable for real-world implementation.

## CONCLUSION

This paper presented the development of an efficient IoT-integrated Arduino-based system for monitoring solar energy applications. The proposed system successfully combines sensing, data processing, and wireless communication to provide real-time monitoring of important parameters such as voltage, current, and temperature. By utilizing IoT technology, the system enables remote access to performance data through a cloud platform, making it easier to analyze and manage solar energy systems.

The results demonstrate that the proposed system offers significant improvements over conventional methods, particularly in terms of real-time monitoring, data accessibility, and overall efficiency. The ability to continuously track system performance helps in early detection of faults and reduces energy losses. Additionally, the use of low-cost components such as Arduino and ESP8266 makes the system economically feasible and suitable for a wide range of applications.

The proposed system provides a reliable, cost-effective, and scalable solution for modern solar energy management. It enhances system performance and supports better utilization of renewable energy resources. The integration of IoT with embedded systems represents a promising approach for future advancements in smart energy systems.

## FUTURE SCOPE

The proposed IoT-integrated Arduino-based solar monitoring system can be further enhanced in several ways to improve its functionality and applicability. One important area of future work is the integration of advanced control techniques such as Maximum Power Point Tracking (MPPT), which can optimize the power output of the solar panel under varying environmental conditions. This would help in maximizing energy efficiency and improving overall system performance.

Another possible enhancement is the incorporation of machine learning or artificial intelligence algorithms for predictive analysis. By analyzing historical data, the system can predict energy generation patterns, detect potential faults in advance, and provide intelligent recommendations for system maintenance and optimization. This would make the system more adaptive and efficient.

The system can also be expanded for large-scale applications such as solar farms or smart grid systems. By connecting multiple units through a centralized cloud platform, it is possible to monitor and manage a large number of solar installations simultaneously. Additionally, the development of a dedicated mobile application with advanced features such as real-time alerts and notifications can further improve user interaction and accessibility.

Furthermore, future improvements may include the use of more advanced communication technologies such as 5G or LoRa for better connectivity in remote areas. Enhancing data security and implementing encryption techniques will also be important to protect sensitive information. Overall, these advancements can make the system more intelligent, scalable, and suitable for next-generation renewable energy solutions.

## REFERENCES

- [1] G. V. Swathi, D. Ramesh, S. V. Krishna, and B. Ganesh, "IoT Based Solar Power Monitoring Using Arduino," *International Journal for Research in Applied Science & Engineering Technology*, vol. 10, no. 5, pp. 1–5, 2022.
- [2] U. Deogade, R. Malkhede, K. Nimje, T. Patil, and R. Burange, "An IoT Based Approach for Monitoring Solar System Parameters Using Arduino Microcontroller," *IJRASET*, 2022.
- [3] V. Kumar and G. Sasikala, "Arduino Based Smart Solar Photovoltaic Remote Monitoring System," *Malaysian Journal of Science*, vol. 41, no. 3, pp. 1–10, 2022.
- [4] V. Gaikar et al., "IoT Based Solar Energy Monitoring System," *Materials Today: Proceedings*, vol. 80, pp. 3540–3545, 2023.
- [5] T. Sutikno, H. S. Purnama, A. Pamungkas, and A. Fadlil, "Internet of Things-Based Photovoltaics Parameter Monitoring System Using NodeMCU ESP8266," *International Journal of Electrical and Computer Engineering*, vol. 11, no. 6, pp. 5578–5587, 2021.
- [6] M. Gopal, T. C. Prakash, N. V. Ramakrishna, and P. Yadav, "IoT Based Solar Power Monitoring System," *IOP Conference Series: Materials Science and Engineering*, vol. 981, no. 3, 2020.

- [7] R. Pimpalkar, A. Sahu, and A. Roy, "A Smart Solar PV Monitoring System Using Internet of Things (IoT)," *Journal of Renewable Energy Systems*, 2025.
- [8] K. Karyadi et al., "Implementation of IoT in the Design of Arduino-Based Solar Panel Monitoring System," *Malikussaleh Journal of Mechanical Science and Technology*, 2024.
- [9] A. Yuan, S. S. Berutu, R. Saputra, and R. S. Sakoikoi, "Design and Development of an IoT-Based Monitoring System for Solar Applications," *International Journal of Computers*, 2024.
- [10] U. Deogade et al., "A Review on Monitoring Solar System Parameters Using IoT," *IJRASET*, 2022.
- [11] V. Gaikar, R. Deshmukh, T. Rajasanthosh Kumar, and S. Chowdhury, "IoT-Based Solar Energy Monitoring System," *Materials Today Proceedings*, 2021.
- [12] T. Sutikno et al., "IoT-Based Monitoring and Control of Solar PV Systems for Performance Optimization," *International Journal of Electrical Engineering*, 2021

