

# An Advanced Dual Input High-Gain DC-DC Converter for Solar Assisted EV Energy Systems

<sup>1</sup>M Shankara Subramanian, <sup>2</sup>J Joe Fredlin, <sup>3</sup>R Aadi Shankar, <sup>4</sup>K Arulvendhan ME

<sup>1</sup>Student, <sup>2</sup>Student, <sup>3</sup>Student, <sup>4</sup>Assistant professor

<sup>1</sup>Department of Electrical and Electronics Engineering,

<sup>1</sup>SRM Institute of Science and Technology, Chennai, India

<sup>1</sup> [sm4342@srmist.edu.in](mailto:sm4342@srmist.edu.in), <sup>2</sup> [jj5074@srmist.edu.in](mailto:jj5074@srmist.edu.in), <sup>3</sup> [rs5192@srmist.edu.in](mailto:rs5192@srmist.edu.in), <sup>4</sup> [arulvenk@srmist.edu.in](mailto:arulvenk@srmist.edu.in)

**Abstract**—This project presents an advanced dual input high-gain DC-DC converter for solar-assisted EV energy systems. The system uses two input sources, where one input is taken from the solar panel and the other from a transformer-based supply. The converter boosts the input voltage to a higher DC level, which is then given to a six-switch inverter. The inverter converts the boosted DC output into a three-phase supply required for the BLDC motor. MATLAB/Simulink simulation and hardware results are used to verify the performance of the system. The results show that the proposed converter provides stable boosted output and is suitable for solar-assisted electric vehicle applications

**Index Terms**—Software Development Kit, Electric Vehicles, Plug-in Hybrid EVs, Solar Powered Operated EVs

## I. INTRODUCTION

Electric vehicles are becoming an important solution for reducing the use of petrol and diesel vehicles. Due to the increase in fuel cost and environmental pollution, many researchers are focusing on renewable-energy-based electric vehicle systems. Among the different renewable sources, solar energy is one of the most useful sources because it is clean, freely available, and suitable for charging or supporting electric vehicle batteries. In a normal solar-assisted electric vehicle system, the solar panel is mainly used to charge the battery, and the battery supplies power to the motor. However, this method does not always use the available solar power effectively. When the battery reaches its required state of charge, the solar power may not be fully used, and some amount of available energy can be wasted. This reduces the overall usefulness of the solar system in electric vehicle applications.

To overcome this problem, this project proposes an Advanced Dual Input High-Gain DC-DC Converter for Solar Assisted EV Energy Systems. The main idea of this project is to use two input sources and boost them to a higher DC voltage suitable for motor drive applications. In this hardware model, one input is taken from the solar panel, and the other input is taken from a transformer-based supply. The transformer section is also used to provide the required supply for the controller and TLP driver circuit. The two input sources are connected to the dual-input super boost DC-DC converter, which increases the input voltage to the required output level. This boosted DC output is then given to an inverter circuit. The inverter consists of six switches and converts the DC output into a suitable three-phase supply for the BLDC motor.

The proposed converter is useful because it can take power from more than one source and improve the voltage level without using a bulky multi-stage conversion system. In electric vehicle applications, the motor requires a stable and sufficient DC-link voltage for proper speed and torque performance. A normal boost converter may not be enough when high voltage gain is required, because it may need a very high duty cycle and can create more losses. Therefore, a high-gain dual-input converter is used in this project to improve the voltage boosting capability and make the system more suitable for EV applications. The converter also helps in reducing power loss by controlling the switching devices properly.

The control circuit plays an important role in the working of the converter. The controller generates PWM pulses, and these pulses are given to the TLP driver circuit. The TLP driver strengthens the pulse signal and provides proper gate pulses to the power switches. In the hardware output, the TLP waveform confirms that the driver circuit is producing the required switching pulses. The boosted output waveform confirms that the converter is able to increase the input voltage and provide a boosted DC output. After boosting, the output is supplied to the inverter and then to the BLDC motor. This complete process shows how solar energy and the additional input source can be used together for an electric vehicle energy system.

The project is also verified using MATLAB/Simulink. The simulation includes the dual-input converter, inverter, and BLDC motor drive system. The output waveforms such as boosted DC voltage, line-to-line voltage, stator current, back EMF, motor speed, and torque are observed to check the performance of the system. The report also mentions that the system is designed to improve solar energy utilization, provide high voltage gain, and maintain stable power flow between the input sources, converter, inverter, and motor. The hardware setup supports the same idea by showing the practical working of the converter, TLP driver circuit, boosted output, and motor drive arrangement. Overall, this project presents a simple and effective method for using solar energy along with another input source to produce a boosted DC output for electric vehicle applications.

## II. LITERATURE REVIEW

Rahul Raj R and Peter K Abraham (2021) Proposes a single-stage buck converter with sine wave inverter using unipolar PWM for battery charging in standalone PV systems, implementing three-stage charging (MPPT, PI-regulated, trickle) to ensure safe operation and improved efficiency.[1]

Zainab A. Ghafour (2022) Presents a high-gain quadratic DC–DC boost converter using single-switch control with only ten components, achieving reduced switch stress and near-constant input current for renewable energy applications.[2]

MD Samiullah (2021) Introduces a split duty super boost (SDSB) converter with a switched-inductor-capacitor network, achieving extremely high voltage gain without magnetic coupling and reduced voltage stress for DC microgrid applications.[3]

Forouzesh (2017) Provides a comprehensive review of high step-up DC–DC topologies, systematically comparing efficiency, voltage gain, and component stress to guide converter selection for solar-assisted EV systems.[4]

Tseng (2019) Proposes an isolated bidirectional interleaved DC–DC converter for renewable and EV applications, achieving high voltage gain, reduced current ripple, and minimized switching losses through soft-switching [5]

Ping Yang (2012) Develops a quadratic boost converter with reduced voltage stress for EV drive systems, maintaining stable DC-link voltage and improved compatibility with motor drive inverters.[6]

Ajami (2015) Integrates coupled inductor and switched-capacitor techniques to achieve ultra-high voltage gain with reduced component stress and effective leakage inductance utilization for EV applications. [7]

Premkumar (2023) Introduces a hybrid high-gain DC–DC converter for PV systems that improves voltage gain without extreme duty cycles, reducing losses and maintaining stable output under varying solar conditions. [8]

Sathyan (2011) Presents an interleaved DC–DC converter for front-end power conditioning, significantly reducing input current ripple and improving dynamic response for motor drive systems.[9]

Zhao and Lee (2003) Proposes high-efficiency step-up DC–DC converter structures minimizing switching losses and semiconductor stress, demonstrating superior performance over conventional boost converters.[10]

Siwakoti and Blaabjerg (2016) Develops a single-switch ultra-step-up DC–DC converter with coupled inductor, minimizing component count and maintaining high efficiency across wide load conditions for renewable systems.[11]

Klein Explores switched-capacitor high-gain converters achieving large step-up ratios without transformers, with soft-switching and continuous input current benefiting PV-assisted EV charging. [12]

### III.METHODOLOGY

The proposed project is developed to obtain a boosted DC output from two input sources and use it for driving a BLDC motor. The overall system mainly consists of a solar panel, transformer-based input supply, dual-input high-gain DC-DC converter, controller circuit, TLP driver circuit, inverter, and BLDC motor. In this project, the solar panel acts as one input source and the transformer-based supply acts as the second input source. The use of two input sources improves the continuity of power supply and makes the system more suitable for solar-assisted electric vehicle applications. When solar energy is available, it can be used as the main input source, and the additional input supply helps to support the converter operation when required.

The input power from the solar panel and transformer supply is given to the dual-input high-gain DC-DC converter. The main function of this converter is to step up the input voltage to a higher DC voltage level. In electric vehicle applications, the motor drive system requires a stable and sufficient DC-link voltage. A normal boost converter may not provide enough voltage gain efficiently, especially when the input voltage is low. Therefore, a high-gain converter topology is used in this project. The converter uses power electronic switches, inductors, diodes, and capacitors to store and transfer energy. During the switching operation, the inductor stores energy when the switch is ON, and releases the stored energy when the switch is OFF. This process helps to increase the output voltage.

The switching operation of the converter is controlled using PWM pulses. The controller generates the required PWM signal according to the converter operation. Since the controller output is not directly suitable for driving the power switches, a TLP driver circuit is used between the controller and the MOSFET switches. The TLP driver strengthens the PWM signal and provides proper gate pulses to the switching devices. It also provides isolation between the control circuit and the power circuit, which improves safety and protects the controller from high-voltage disturbances. In the hardware result, the TLP output waveform confirms that the driver circuit is producing proper switching pulses for controlling the switches.

After the two input sources are boosted through the converter, the boosted DC output is obtained at the converter output side. A capacitor is used at the output to reduce ripple and make the DC voltage smoother. This boosted DC voltage is then given to the inverter circuit. The inverter used in this project consists of six switches arranged in a three-phase bridge structure. Since the BLDC motor cannot run directly from DC supply, the inverter converts the boosted DC voltage into a three-phase output. This three-phase output is then supplied to the BLDC motor. The inverter switching sequence is controlled in such a way that the motor receives the required phase excitation for smooth rotation.

The complete system is also designed and tested in MATLAB/Simulink. The simulation model includes the dual-input converter, inverter, and BLDC motor drive system. The simulation is used to observe the performance of the system before verifying it in hardware. Different waveforms such as boosted DC output voltage, line-to-line voltage, stator current, back

EMF, motor speed, reference speed, and torque are observed. These waveforms help to understand whether the converter is producing the required boosted output and whether the BLDC motor is operating properly. The report also explains that the system is developed to improve solar energy utilization, achieve high voltage gain, and maintain stable power flow between the input sources and the motor drive.

The hardware prototype is built using components such as transformers, solar panel, MOSFETs, TLP driver board, controller board, inductors, diodes, capacitors, inverter section, and BLDC motor. In the hardware setup, four transformers are used. One transformer is used as one of the input sources, while the solar panel is used as the second input source. The transformer section also supplies power to the controller and TLP driver circuit. The hardware output waveforms are observed using a DSO. The TLP driver output waveform shows the PWM pulse given to the switches, and the boosted output waveform shows that the converter is stepping up the input voltage. These hardware results support the simulation results and prove the practical working of the proposed system.

Thus, the methodology of this project follows a step-by-step process: collecting power from two input sources, boosting the voltage using the dual-input high-gain DC-DC converter, controlling the switches using PWM pulses through the TLP driver, smoothing the output using a capacitor, converting the boosted DC into three-phase supply using the inverter, and finally driving the BLDC motor. This method helps to improve the voltage level, make better use of solar energy, and provide a suitable output for electric vehicle motor drive applications.

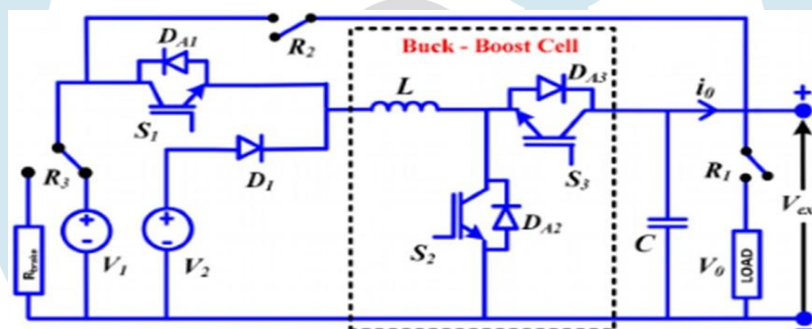

Fig.1. Circuit diagram for An Advanced Dual Input High-Gain DC-DC Converter for Solar Assisted EV Energy Systems..

#### IV. ANALYTICAL STUDY AND SIMULATION DIAGRAM

The simulation diagram of the proposed system is developed in MATLAB/Simulink to study the complete working of the dual input high-gain DC-DC converter for solar-assisted EV applications. The simulation mainly includes the solar input source, battery or secondary input source, dual-input super boost converter, PWM control section, three-phase inverter, and BLDC motor. The purpose of the simulation is to check whether the converter can boost the input voltage properly and supply a stable DC output to the motor drive system. In the simulation model, the solar input is considered as the main renewable source, while the second input supports the system when additional power is required. The project details mention that the MATLAB model includes solar panel supply, 100 V lithium-ion battery, dual input converter, universal bridge inverter, and three-phase BLDC motor.

The first stage of the simulation is the dual-input power source section. In this part, DC power is taken from the solar panel and the secondary source. The solar panel output depends on solar irradiation and temperature, so its voltage and current may vary during operation. To maintain continuous power flow, the second input source is connected along with the solar panel. This arrangement helps the system to avoid sudden voltage drops at the DC-link side. The main advantage of this dual-input structure is that it improves power availability and allows the converter to work even when the solar input is not sufficient. The system is designed in such a way that the available input power is properly managed before it is given to the converter.

The next stage is the dual-input super boost DC-DC converter. This is the important part of the simulation because it increases the input voltage to a higher DC level. The converter uses switching devices, inductors, diodes, and capacitors for boosting operation. During the ON condition of the switch, the inductor stores energy. During the OFF condition, the stored energy of the inductor is released and added with the input voltage, which produces a boosted output voltage. The report explains that the super boost converter is used because conventional boost converters need a very high duty cycle to obtain high voltage gain, which can reduce efficiency and increase stress on switches.

The switching operation of the converter is controlled using PWM pulses. In the simulation, the PWM control adjusts the duty cycle of the switching device according to the required output voltage. This helps to maintain a stable DC output even when there is a change in input voltage or load condition. The output capacitor is connected at the converter output to reduce ripple and make the DC-link voltage smoother. A stable DC-link is very important because the inverter and motor performance mainly depend on the quality of the DC supply. If the DC output has more ripple, it can affect the inverter output and cause disturbance in the motor current and torque.

After the boosted DC output is obtained, it is supplied to the three-phase inverter. The inverter is modeled using a universal bridge. The main function of the inverter is to convert the boosted DC voltage into a three-phase AC supply required by the BLDC motor. The inverter consists of six switches, and these switches are triggered in a proper sequence. This switching sequence creates the required three-phase voltage for the motor. The report also explains that the inverter converts the regulated DC output into controlled AC supply, and this stable DC voltage helps to reduce torque pulsation in the motor.

The BLDC motor section is connected at the output of the inverter. Since the BLDC motor requires proper electronic commutation, the inverter switching is controlled based on the required motor operation. In the simulation, motor parameters such as stator current, back EMF, rotor speed, reference speed, and electromagnetic torque are observed. These waveforms are useful to understand whether the motor is running smoothly or not. The stator current waveform shows the current drawn by the motor, while the back EMF waveform shows the voltage generated due to rotor movement. A balanced current and back EMF indicate proper operation of the motor drive system.

The speed and torque waveforms are also important for analyzing the system performance. During starting, the motor needs higher torque to overcome inertia, so the torque may show an initial rise. After the motor reaches steady-state operation, the torque becomes more stable. Similarly, the rotor speed gradually increases from zero and reaches the reference speed. The report mentions that the simulation observes variables such as stator current, back EMF, rotor speed, and electromagnetic torque, and the rotor speed reaches the 1500 RPM reference value during operation.

From the simulation study, it is clear that the proposed dual-input high-gain converter is able to boost the input voltage and provide a suitable DC-link voltage for the inverter. The inverter then produces the required three-phase output for the BLDC motor. The observed simulation waveforms, such as DC output voltage, line-to-line voltage, stator current, back EMF, speed, and torque, confirm the proper operation of each stage of the system. Overall, the simulation proves that the proposed converter can maintain stable power flow from the input sources to the motor drive, and it is suitable for solar-assisted electric vehicle energy systems.

**V.EXPERIMENT RESULTS**

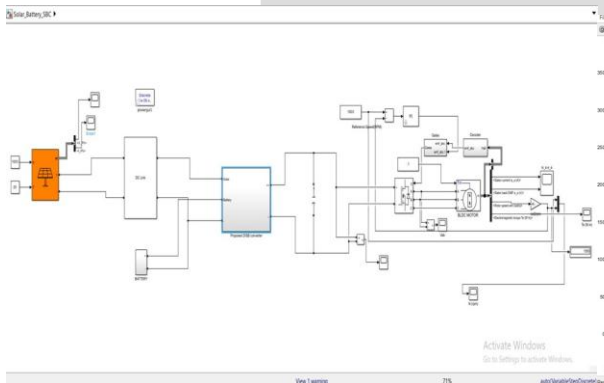

Fig.2. Simulation Diagram

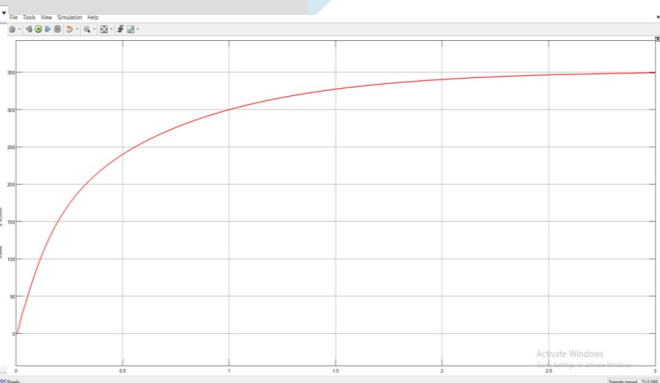

Fig.3. DC Voltage Waveform

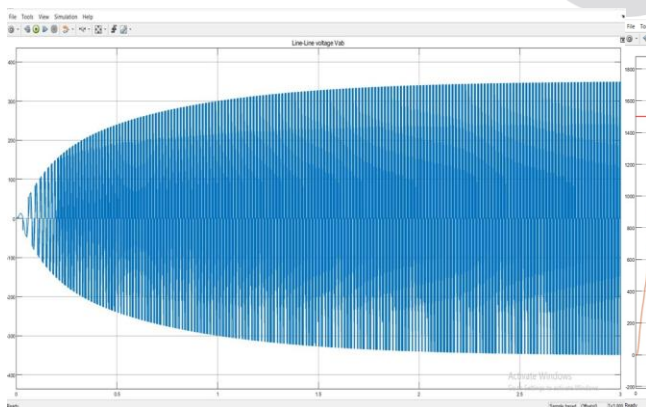

Fig.4. Line to Line Voltage.

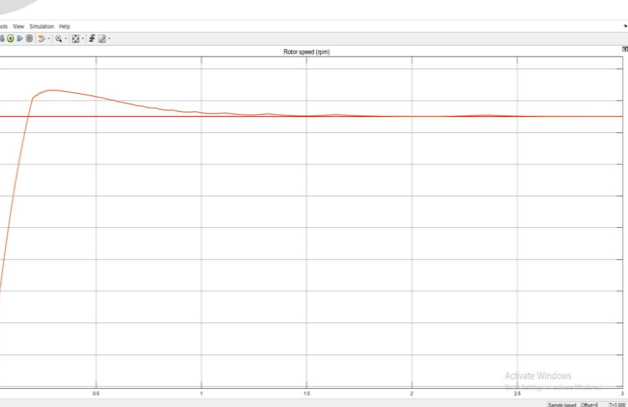

Fig.5. Motor Speed and Reference Speed

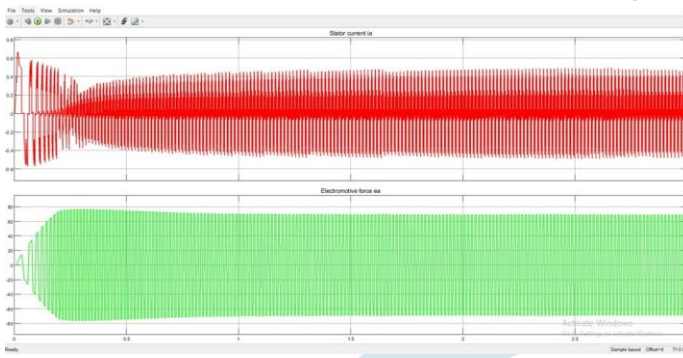

Fig.6. Stator Current and Back EMF.

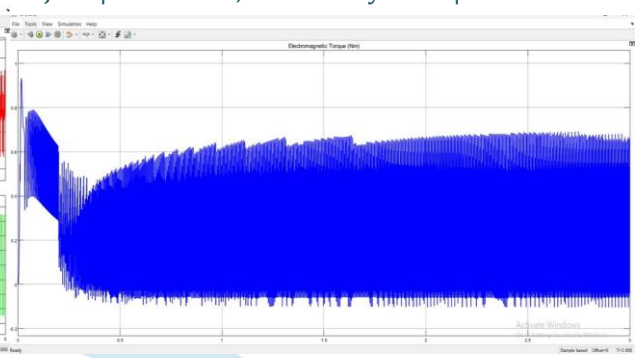

Fig.7 Torque

The hardware prototype of the proposed dual input high-gain DC-DC converter was developed and tested to verify the practical working of the system. The setup consists of a solar panel, transformer-based input supply, converter circuit, controller section, TLP driver circuit, inverter section, and BLDC motor. In this project, the solar panel is used as one input source, while the transformer supply is used as the second input source. Apart from acting as one of the inputs, the transformer section also provides the required supply for the controller and TLP driver circuit. This arrangement helps the complete hardware setup to operate in a stable manner.

During testing, the controller generated the required PWM pulses for switching the power devices in the converter circuit. Since the controller output cannot directly drive the MOSFET switches, the PWM signal was given to the TLP driver circuit. The TLP driver increases the pulse level and gives proper gate pulses to the switches. The TLP output waveform observed in the DSO shows a clear pulse waveform, which confirms that the driver circuit is working properly. This is an important result because the boosting operation of the converter mainly depends on proper switching of the MOSFETs.

The boosted output waveform was also observed from the hardware setup. The waveform shows that the dual input converter is able to increase the input voltage and produce a boosted DC output. The capacitor connected at the output side helps to reduce the ripple and makes the output more stable. This boosted DC voltage is suitable for supplying the inverter stage. From the hardware observation, it can be understood that the converter is performing the voltage step-up operation as expected

After the boosted DC output is obtained, it is supplied to the inverter section. The inverter consists of six switches arranged in a three-phase bridge form. The function of the inverter is to convert the boosted DC voltage into a three-phase output required for the BLDC motor. Since the BLDC motor requires proper phase excitation for smooth rotation, the inverter plays an important role in the motor drive section. The hardware setup confirms the complete power flow from the input sources to the converter, then to the inverter, and finally to the BLDC motor.

The experimental waveforms support the simulation results obtained from MATLAB/Simulink. In the simulation, the DC output voltage, line-to-line voltage, stator current, back EMF, motor speed, and torque waveforms were observed to study the performance of the system. In the hardware side, the TLP driver output waveform confirms proper switching pulse generation, and the boosted output waveform confirms the voltage boosting operation. Therefore, both simulation and hardware results show that the proposed system is suitable for solar-assisted EV energy applications.

From the experimental study, it is clear that the proposed converter can operate successfully with two input sources and produce a boosted DC output. The TLP pulse waveform proves the proper operation of the driver circuit, while the boosted output waveform proves the voltage step-up capability of the converter. The obtained output can be further used by the inverter to drive the BLDC motor. Hence, the hardware results validate the practical performance of the proposed dual input high-gain DC-DC converter

**VI.HARDWARE RESULTS**

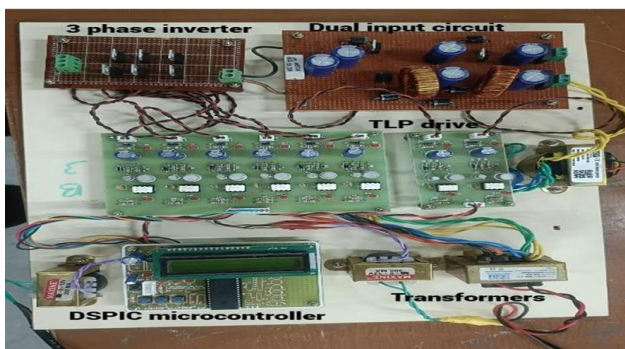

Fig. 8. Hardware Kit

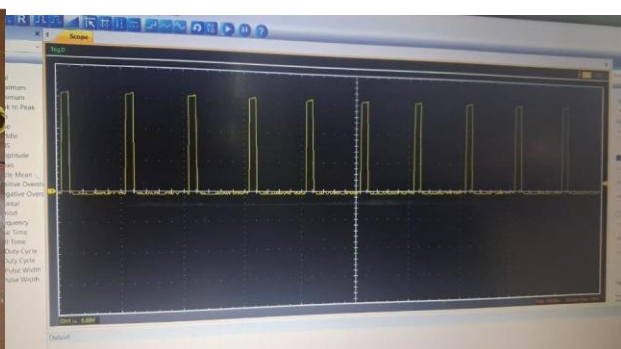

Fig. 9. Drive Output

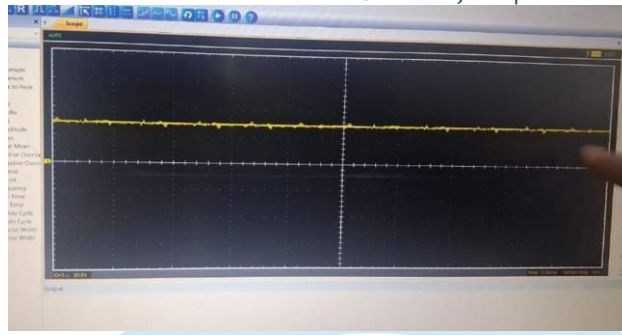

Fig. 10. Converter Output

## VII. CONCLUSION

The proposed project, Advanced Dual Input High-Gain DC-DC Converter for Solar Assisted EV Energy Systems, was designed and tested to obtain a boosted DC output from two input sources. In this system, the solar panel acts as one input source, while the transformer-based supply acts as the second input source. The transformer section is also used to supply power to the controller and TLP driver circuit. The dual input converter successfully boosts the input voltage to a higher DC level, which is suitable for feeding the inverter and driving the BLDC motor.

The working of the system was verified using both MATLAB/Simulink simulation and hardware implementation. In the simulation, waveforms such as DC output voltage, line-to-line voltage, stator current, back EMF, motor speed, and torque were observed to study the performance of the system. These results showed that the converter can provide a stable boosted output and support proper motor operation. In the hardware setup, the TLP driver output waveform confirmed the generation of proper switching pulses for the MOSFET switches, and the boosted output waveform confirmed the voltage step-up operation of the converter.

From the overall results, it can be concluded that the proposed dual input high-gain DC-DC converter is suitable for solar-assisted electric vehicle applications. The system helps to use solar energy along with an additional input source and produces a boosted DC voltage required for the motor drive system. The inverter with six switches converts this boosted DC output into a three-phase supply for the BLDC motor. Thus, the project proves that a dual input converter can improve voltage gain, support stable power flow, and provide an effective energy conversion method for EV-based applications.

## VIII. ACKNOWLEDGMENT

The authors would like to express their sincere gratitude to Mr. K Arulvendhan, SRM Institute of Science and Technology, for his invaluable guidance, encouragement, and continuous support throughout the course of this research. His insights and expertise have been instrumental in shaping the direction and execution of the project. We also extend our thanks to the faculty and staff of the Department of Electrical and Electronics Engineering, SRM Institute of Science and Technology, for providing the necessary resources and a conducive research environment. This work would not have been possible without their collective contribution and support.

## REFERENCES

- [1] Ting-Lien Wu (2014), "Dual-Input DC-DC Power Converter for Solar Battery Charger," National University of Tainan, Department of Green Energy Technology, pp. 1–4.
- [2] Furkan Akar, Yakup Tavlasoglu, and Bulent Vural (2013), "PV/Battery Hybrid Energy System via a Double Input DC/DC Converter for Dynamic Loads," Yildiz Technical University, Electrical Engineering, pp. 1–6.
- [3] Asuaki Furusho, Yasuyuki Noto, and Kansuke Fujii (2018), "1 MW Power Conditioning System with Multiple DC Inputs for PVs and Batteries," 2018 International Power Electronics Conference (IPEC-Niigata – ECCEAsia), pp. 1–6.
- [4] Rahul Raj R and Peter K. Abraham (2021), "Sine Wave Inverter with Three Stage Battery Charger for Solar Photovoltaic Application," 2021 IEEE Madras Section Conference (MASCON), pp. 1–6.
- [5] Zainab A. Ghafour, Ahmed R. Ajel, and Naseer M. Yasin (2022), "A New High Gain Quadratic DC-DC Boost Converter for Photovoltaic Applications," 10th IEEE International Conference on Smart Grid (icSmartGrid), pp. 1–6.
- [6] J. Barsana Banu (2013), "Modeling and Simulation of Isolated Full Bridge with Super Lift Boost Converter," 4th International Conference on Power Engineering, Energy and Electrical Drives (POWERENG), pp. 1–6.

- [7] Cerine Kallukaran, L. Unnikrishnan, and Rinu Alice Koshy (2018), "Multi-Input Interleaved DC-DC Converter with Low Current Ripple for Electric Vehicle Application," 2018 IEEE International Conference on Current Trends toward Converging Technologies (ICCTCT), pp. 1–6.
- [8] MD Samiullah, Atif Iqbal, Imtiaz Ashraf, and Sandy Rahme (2021), "Split Duty Super Boost Converter for High Voltage Applications in a DC Microgrid," IEEE Access, vol. 9, pp. 101076–101088..
- [9] P. Srinivasa Rao Nayak and N. Laxman (2021), "Design and Simulation of Buck-Boost Type Dual Input DC-DC Converter for Battery Charging Application in Electric Vehicle," 2021 International Conference on Sustainable Energy and Future Electric Transportation (SEFET), pp. 1–6.
- [10] F. Khoucha, A. Benrabah, O. Herizi, and A. Kheloui (2013), "An Improved MPPT Interleaved Boost Converter for Solar Electric Vehicle Application," 4th International Conference on Power Engineering, Energy and Electrical Drives (POWERENG), pp. 1– 6.
- [11] M. Forouzesh, Y. P. Siwakoti, S. A. Gorji, F. Blaabjerg, and B. Lehman (2017), "Step-Up DC–DC Converters: A Comprehensive Review of Voltage Boosting Techniques, Topologies, and Applications," IEEE Transactions on Power Electronics, vol. 32, no. 12, pp. 9143–9178.
- [12] A. Ajami, H. Ardi, and A. Farakhor (2015), "A Novel High Step-Up DC/DC Converter Based on Integrating Coupled Inductor and Switched Capacitor Techniques," IEEE Transactions on Power Electronics, vol. 30, no. 8, pp. 4251–4263.
- [13] Y. Tang, T. Wang, and D. Fu (2014), "Multicell Switched-Inductor and Switched-Capacitor Combined DC–DC Converter for High Step-Up Voltage Gain," IEEE Transactions on Power Electronics, vol. 29, no. 9, pp. 4741–4750.
- [14] M. Prudente, L. L. Pfischer, G. Emmendoerfer, E. F. Romaneli, and R. Gules (2008), "Voltage Multiplier Cells Applied to Non-Isolated DC–DC Converters," IEEE Transactions on Power Electronics, vol. 23, no. 2, pp. 871–887.

IJRTI